



NEW GENERATION PRO-III



KMT PRO-III APP
Cut Calculator





GENERATION OF 90,000PSI PUMP KMT STREAMLINE PRO®-III



SUPRAlife seals guaranteed for 500 hours (Terms & conditions apply)



Metal-to-metal seal design is more durable with no wear in the high pressure cylinder bore



Tie Rod Design with hydraulic loading tensioner guarantees longer lifetime of SUPRAlife seals



Stainless steel liner adds extra protection to ceramic plunger for longer life



Topworks can be retrofitted to PRO-I & PRO-II Pumps

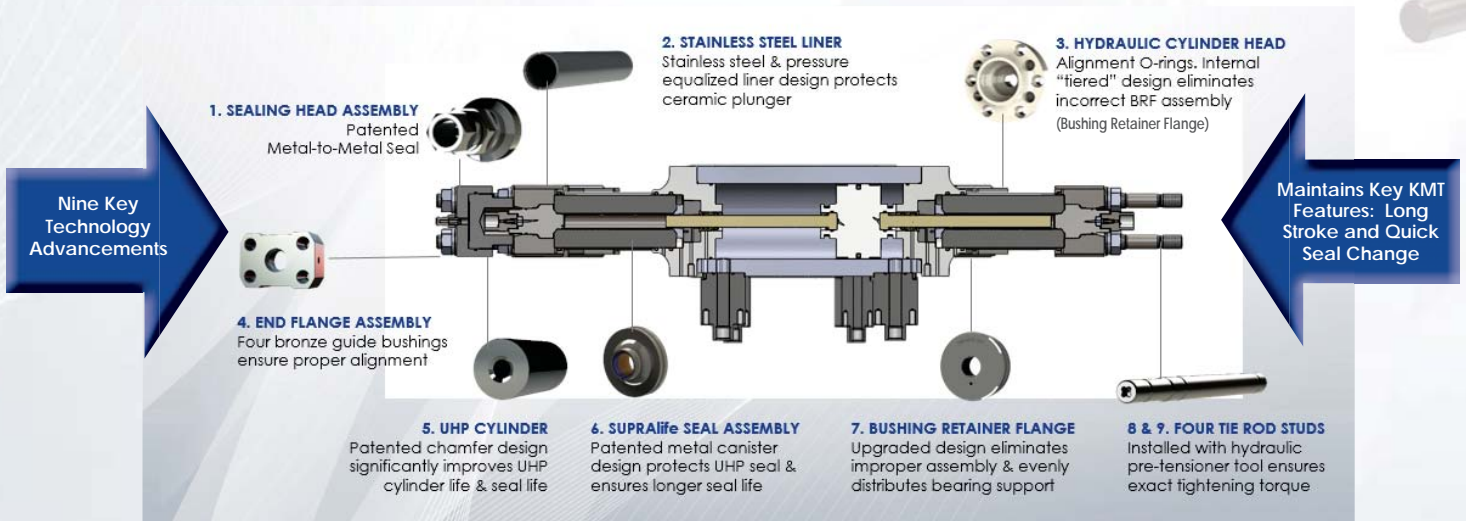

KMT PRO-III ADVANTAGE

Designed for maximum productivity, profitability, and extended performance. Combines the lowest cost of operating a waterjet pump with outstanding KMT Genuine Service support to provide optimum value.

FASTER

Increased Pressure
Accelerates Abrasive
at Highest Velocity

LEANER

Lower Abrasive Cost
Optimized Taper
No Secondary Finishing

SMARTER

Double Productivity
Lowest Cost per Part
Increase Capacity

HARD Materials

No Heat Affected Zone
Cut Conductive and
Nonconductive

THICK Materials

14" Aluminum
12" Cast Steel
Near Net Cutting

LAYERED Materials

Save Time & Money
Cutting Layered Parts
Simultaneously



60,000PSI vs. 90,000PSI Comparison

The diagrams below shows the KMT PRO-III 90,000PSI (60hp and 125hp) pumps compared to standard 60,000PSI (50hp) waterjet pumps. The data demonstrates when cutting 1 inch aluminum at 90,000PSI, there is a significant improvement in productivity, lower cost per part and substantial abrasive savings.

Increase Productivity/Profitability



1,000 Parts/Day
x \$1/Part
\$1,000



1,500 Parts/Day
x \$1/Part
\$1,500

Lowest Cost Per Part



14:03
7"
\$8.30

Cutting Time
In/Min
Cost Per Part



9:42
11"
\$5.89

Reduce Abrasive Cost



14/43
1.43
10 hours/day = 50 hours
\$1,285
\$66,820/Year

Nozzle
Abrasive lbs/min
Hours/Week
Weekly \$\$
JOB TOTAL COST
(Same Quantity of Parts)



11/30
1.08
6.9 hours/day = 35 hours
\$615
\$31,980/Year

**Total Job
Cost Savings
\$34,840
Year!**

Increase Capacity



* 60,000PSI Parts
Shown for
Comparison

PRO-III SPECIFICATIONS

DESCRIPTION	60
Motor Rating	60hp (45kw)
Pressure Range (Deadhead)	90,000psi (6.200 bar)
Max. Flow Rate at Max. Pressure (60 Hz)	0.78 gal/min (2.9 lpm)
Length	83.7" (2,126 mm)
Width	53.7" (1,364 mm)
Height	59.3" (1,506 mm)
CUTTING WATER CIRCUIT	
Attenuator Volume	.42 gal (1.6 L)
Cutting Water Inlet Pressure	35-85psi (2.41-5.86 bar)
Min. Cutting Water Inlet Flow	4.0 gal (15.1 L)
Low Pressure Filter	10 µm abs.
CONTROLS & ELECTRIC	
Nom. Current at 480V/60Hz (Full Load Amp)	70 A
HYDRAULICS	
Hydraulic Tank Capacity	55.8 gal (211 L)
Oil Level and Temperature Control	Sensor
STANDARD FEATURES	
Adjustable Booster Pump	
Cutting Water Inlet Shut-Off Valve	
Dual Pressure Setting	
Oil Drip Pan	
Dump Valve	
Water Cooled Heat Exchanger	
Cover	
Doors	
High Pressure Transducer	
OPTIONAL FEATURES	
Air Cooled Heat Exchanger	
Motor Rewind for 575v & CSA	
Proportional Control	
Redundant Intensifier	
Soft Start/Electronic/Y-Delta	



DESCRIPTION	125
Motor Rating	125hp (93.2kw)
Pressure Range (Deadhead)	90,000psi (6.200 bar)
Max. Flow Rate at Max. Pressure (60 Hz)	1.59 gal/min (6.0 lpm)
Length	88" (2,230 mm)
Width	59.09" (1,500 mm)
Height	61.12" (1,552 mm)
CUTTING WATER CIRCUIT	
Attenuator Volume	.42 gal (1.6 L)
Cutting Water Inlet Pressure	35-85psi (2.41-5.86 bar)
Min. Cutting Water Inlet Flow	8 gal (30 L)
Low Pressure Filter	10 µm abs.
CONTROLS & ELECTRIC	
Nom. Current at 480V/60Hz (Full Load Amp)	70 A
HYDRAULICS	
Hydraulic Tank Capacity	110 gal (416 L)
Oil Level and Temperature Control	Sensor
STANDARD FEATURES	
Adjustable Booster Pump	
Cutting Water Inlet Shut-Off Valve	
Dual Pressure Setting	
Oil Drip Pan	
Dump Valve	
Water Cooled Heat Exchanger	
Cover	
Doors	
High Pressure Transducer	
Proportional Control	
Soft Start	
OPTIONAL FEATURES	
Air Cooled Heat Exchanger	
Motor Rewind for 575v & CSA	
Electronic/Y-Delta Start	



NOTE: Applies to all pumps:
 Min. pneumatic air pressure 86 PSI
 Max. pneumatic air flow rate 1 SCFM
 Ambient temp. @ Oil-to-Water cooling circuit 41 - 106 °F
 Ambient temp. @ Oil-to-Air cooling circuit 41 - 86 °F



KMT Genuine Parts & Service

Your business is worth it.



- SUPRAlife seals guaranteed for 500 hours*
- Onsite Post Installation Assessment by KMT Genuine Service Technician
- Standard One Year Warranty with Option for Extended Warranty
- Includes Two Preventive Maintenance Visits in the First Year of PRO-III Ownership
- Be Secure Knowing your PRO-III is Serviced by the Experts at KMT Genuine Service
- Maintaining Optimal Performance, Efficiency and Reliability Through the Life of your Intensifier
- Setting the Standard for Service and Support in the Waterjet Industry

THE BEST VALUE IN THE WATERJET INDUSTRY



WATERJET PIONEERS
 GLOBAL NETWORK OF OEM'S
 BROADEST RANGE OF WATERJET SYSTEMS

KMT Waterjet Systems Inc.
 635 West 12th Street
 Baxter Springs, KS 66713 USA
 620-856-2151 • 800-826-9274
 sales@kmtwaterjet.com
 kmtwaterjet.com