



**TRILINE™
DIRECT DRIVE PUMP**

OPERATION AND MAINTENANCE MANUAL



NOTICE

This document contains subject matter in which KMT Waterjet Systems has proprietary rights. Recipients of this document shall not duplicate, use or disclose information contained herein, in whole or in part, for other than the purpose for which this manual was provided.

KMT Waterjet believes the information described in this manual to be accurate and reliable. Much care has been taken in its preparation; however, the Company cannot accept any responsibility, financial or otherwise, for any consequences arising out of the use of this material. The information contained herein is subject to change, and revisions may be issued advising of such changes and/or additions.

KMT WATERJET SYSTEMS 2016



KMT Waterjet Systems
635 West 12th Street
PO 231
Baxter Springs, KS 66713-0231

Phone: (800) 826-9274
Fax: (620) 856-5050

TABLE OF CONTENTS

Title Page
Notice
Table of Contents
Appendix

<i>Section</i>	<i>Page</i>
1 Introduction.....	1-1
1.1 Overview.....	1-1
Operational Overview.....	1-2
1.2 Product Nameplate.....	1-4
1.3 Intended Use of Equipment.....	1-4
1.4 Safety.....	1-5
Safety Precautions.....	1-5
Training.....	1-7
Personal Protective Equipment.....	1-7
Additional Precautions.....	1-7
Lockout/Tagout Procedure.....	1-8
Emergency Medical Treatment.....	1-8
1.5 Worldwide Product Support.....	1-9
1.6 Spare Parts.....	1-9
2 Installation.....	2-1
2.1 Overview.....	2-1
2.2 Installation Summary.....	2-1
2.3 Installation Requirements.....	2-2
Transporting.....	2-3
2.4 Power Requirements.....	2-3
2.5 Service Connections.....	2-4
Inlet Water Requirements.....	2-5
Drain.....	2-5
Plant Air.....	2-6
2.6 High Pressure Piping.....	2-6
Measurements and Dimensions.....	2-8
Power Coning.....	2-9
Power Threading.....	2-9
2.7 High Pressure Connections.....	2-10
Standard Connections.....	2-10
Anti-Vibration Connections.....	2-11
2.8 Commissioning.....	2-12
2.9 Decommissioning.....	2-13

3	Maintenance	3-1
3.1	Overview	3-1
3.2	Maintenance	3-1
	Daily Inspection	3-1
	Periodic Maintenance.....	3-1
	Mandatory Maintenance Schedule.....	3-3
	High Pressure System Maintenance.....	3-5
3.3	Maintenance Precautions	3-5
4	Operation.....	4-1
4.1	Overview	4-1
4.2	Preparing the Pump for Startup.....	4-2
4.3	Starting the Pump.....	4-3
5	Service Procedures.....	5-1
5.1	Overview	5-1
5.2	Service and Maintenance Overview	5-2
	Specialized Maintenance Tools	5-3
	Mandatory Maintenance Schedule.....	5-3
5.3	High and Low Pressure Connections	5-4
5.4	Loading and Unloading the Tie Rods	5-5
	Unloading the Tie Rods	5-6
	Loading the Tie Rods.....	5-8
5.5	Minor Maintenance Kit.....	5-11
	Lapping the Discharge Check Valve Body.....	5-15
	Discharge Check Valve Assembly Installation.....	5-16
	End Cap Assembly.....	5-16
	Plunger Torque Verification	5-17
	Subplate Adapter Installation.....	5-17
	Dynamic Seal Installation	5-17
	High Pressure Cylinder Installation	5-19
	Inlet Check Valve Assembly Installation	5-19
	End Cap Installation.....	5-20
	Pressure Control Valve Maintenance.....	5-21
5.6	Major Maintenance Kit	5-23
	Discharge Check Valve Assembly Installation.....	5-27
	End Cap Assembly.....	5-28
	Plunger Removal and Installation	5-28
	Subplate Adapter Installation.....	5-29
	Dynamic Seal Installation	5-29
	High Pressure Cylinder Installation	5-30
	Inlet Check Valve Assembly Installation	5-31
	End Cap Installation.....	5-32
	Pressure Control Valve Maintenance.....	5-32
	Replacing the Belts	5-34
5-7	Pressure Control Valve Maintenance Kit	5-35

5.8	Low Pressure Filter Maintenance	5-39
5.9	Servicing the Crankcase.....	5-40
	Lubricating the Pump.....	5-40
	Tensioning and Aligning the Belt Drive.....	5-40
	Replacing the Belts	5-43
5-10	Pressure Loading Tool Maintenance Kit	5-43
	Bleeding the Pressure Loading Tool.....	5-46
6	Troubleshooting	6-1
6.1	Overview.....	6-1
6.2	Troubleshooting Guide	6-2
	Short Component Life.....	6-9
	Troubleshooting Illustration.....	6-11
7	Specifications	7-1
7.1	Overview.....	7-1
7.2	Installation Specifications.....	7-1
7.3	Pump Specifications.....	7-2
	Plant Air	7-2
7.4	Water Quality Standards	7-3
8	Parts List.....	8-1
8.1	Overview.....	8-1
8.2	Index	8-2

APPENDIX

Exhibit

Electrical Schematic
Material Safety Data Sheets



SECTION 1

INTRODUCTION

1.1 Overview

The TRILINE™ direct drive pump is a powerful, high pressure waterjet cutting tool designed for minimum maintenance and reliable performance.

Table 1-1
TRILINE™ Direct Drive Pump

Motor Horsepower Rating		Maximum Operating Pressure	Water Volume	Maximum Single Orifice Diameter (at full pressure)	Motor Speed
HP	Kw				
30	22	55,000 psi (3,792 bar)*	0.84 gpm (3.18 L/min)	0.012” (0.30 mm)	720 rpm

**Note:* Maximum pressure with cutting head valve open is 55,000 psi (3,792 bar). Maximum pressure with cutting head valve closed is 60,000 psi (4,137 bar).

The pump is available in three configurations, with covers, without covers and free standing with wall mounted electrical, display and filter assembly. All configurations feature single or dual pressure operation.



Operational Overview

Supply water is introduced through the 1/2-inch NPT connection on the bulkhead of the pump and is routed to the normally closed solenoid valve.

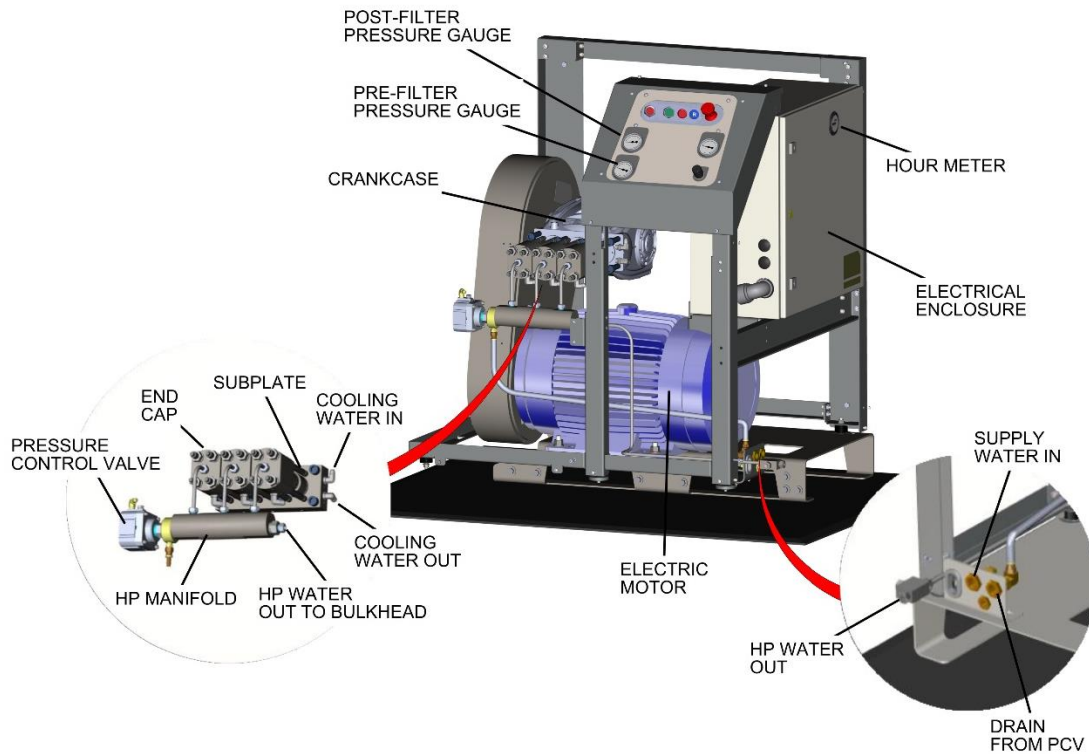

When the pump is started, the solenoid valve opens and allows water to flow through the valve. The inlet water pressure is displayed on the pre-filter pressure gauge on the control panel.

The water passes through the coarse filter assembly and is routed to the subplate to cool the high pressure cylinders. When the water returns from the subplate, it passes through a fine filter and is sent to the low pressure manifold.

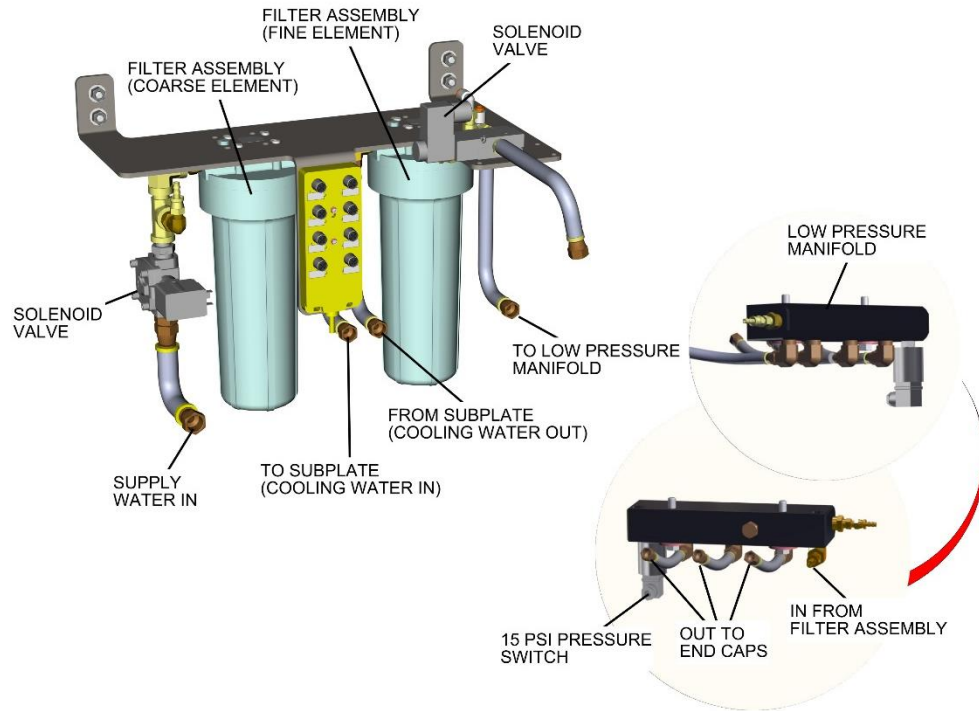

Water pressure can be observed on the post-filter pressure gauge on the control panel. Water pressure is monitored by a 15 psi (1 bar) pressure switch on the low pressure manifold. If the pressure falls below 15 psi (1 bar) the red indicator light on the control panel will illuminate indicating low inlet water pressure.

From the manifold, supply water is sent to each of the end caps in the high pressure assembly. The motor turns the crankcase causing the three plungers in the high pressure system to stroke.

On the inlet stroke, the plunger retracts creating a low pressure area and allowing the inlet poppet to open. Inlet water fills the high pressure cylinder, forcing the discharge poppet to close.

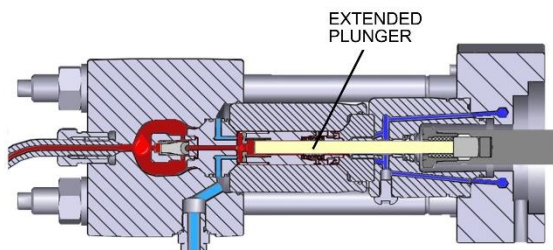
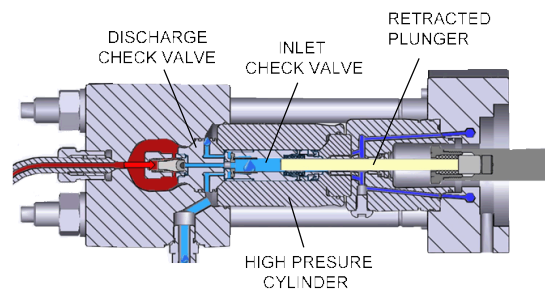

On the pressure stroke, the plunger extends pressurizing and compressing the water. The inlet poppet is forced to close, sealing the passage. As the water is pushed through the discharge check valve, the discharge poppet opens. The water enters the end cap and is routed to the high pressure manifold.

High pressure water exits the high pressure manifold and is routed to the cutting head. The pressure control valve regulates the outlet pressure. Excess pressure, above the requested pressure, passes through the drain on the pressure control valve.

1.2 Product Nameplate

The product nameplate contains the pump model, serial, identification and part numbers for each individual machine.

Figure 1-1: Product Nameplate

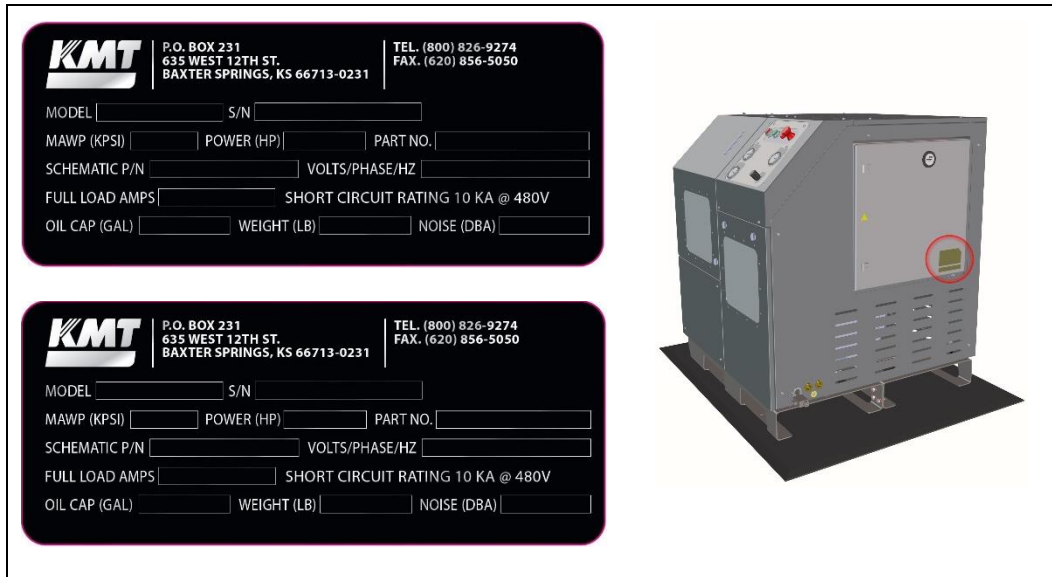

1.3 Intended Use of Equipment

The TRILINE™ pump has been designed solely for the generation of high pressure cutting water for industrial and commercial applications in non-explosive atmospheres, such as cutting parts from raw material on an x-y table.

The intended working liquid is potable water. The use of any other liquid should only be considered after consulting with KMT Waterjet. Use of the pumps for hydrostatic testing purposes should also only be considered after consulting with KMT.

The intended use further includes compliance with the operating, maintenance and repair conditions prescribed by the manufacturer as detailed in this manual.



This machine is intended solely for the purpose described above. Use of the machine for a different purpose or conversion of the machine without the written agreement of the manufacturer shall not be considered as intended use. The manufacturer shall not be liable for damage incurred as a result in such cases. The risk shall be borne solely by the owner.

1.4 Safety

The high pressure waterjet cutting system is a high energy cutting tool capable of cutting many dense or strong materials. Do not touch or be exposed to high pressure water. High pressure water will penetrate all parts of the human body. The liquid stream and the material ejected by the extreme pressure can result in severe injury.

Safety Precautions

The operator and service personnel shall pay particular attention to the safety precautions detailed in Table 1-2.

Table 1-2
Safety Precautions



The electrical enclosure and motor junction box can present an electrical shock hazard. Always disconnect and lockout the main power before opening the enclosure.

Always disconnect and lockout the main power and the circuit breaker/disconnect on the enclosure door before performing any type of maintenance.



Never open or perform maintenance on the unit with the main power disconnect on. Before any maintenance or repairs are performed, the machine shall be isolated, and rendered inoperative.

The lockout/tagout procedure applies to any employee who operates and/or performs service or maintenance on the machine.



The surface of high pressure water components become hot during normal operation. Failed, or failing components, can become extremely hot during operation.



High pressure water can remain in the system even when the pump has been shut off. All pressure can be safely bled from the system by opening the high pressure cutting water valve for a few seconds after shutting off the pump.

Pressing the emergency stop button turns the control power to the pump off, stops the pump and bleeds the high pressure water.

Table 1-2
Safety Precautions



The work area around the equipment shall be clean and free of debris and oil spills.

To reduce the likelihood of slip, trip and fall hazards, it is the responsibility of the user of this equipment to clean up spills near the pump.



All personnel involved in the installation, operation and/or service of the pump must carefully read, understand and follow the procedures in this manual to avoid creating unsafe conditions, risking damage to the equipment, or personal injury.



The weight of the machine is not evenly distributed from one end to the other. The machine can be safely lifted from either end or either side.

When the machine is removed from the crate, note the position of the fork pockets on the bottom of the machine. The pockets are positioned in relationship to the center of gravity to balance the weight on the pallet jack or forklift.

Safety precautions and warnings for specific procedures are emphasized throughout this manual as illustrated in the following examples. These precautions must be reviewed and understood by operating and maintenance personnel prior to installing, operating or servicing the machine. Adherence to all Warnings, Cautions and Notes is essential to safe and efficient service and operation.



Warnings emphasize operating or service procedures, or conditions that can result in serious personal injury or death.



Cautions emphasize operating or service procedures, or conditions that can result in equipment damage or impairment of system operation.

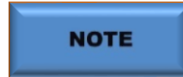

Notes provide additional information that can expedite or improve operating or service procedures.

Training

All personnel operating, servicing or working near the waterjet cutting equipment shall adhere to all safety precautions described in this manual, as well as the applicable plant safety precautions.

Only KMT factory trained, qualified personnel shall service, maintain and operate the equipment.

Personal Protective Equipment

All maintenance and operating personnel shall practice and promote safety at all times to avoid potential injury and unnecessary downtime. Maintenance procedures should be performed in a well-ventilated area.



Any personnel in proximity of the equipment are to wear proper personal protective equipment to include at a minimum, safety glasses with side shields and hearing protection.

In addition to safety glasses with side shields, it is recommended that maintenance personnel wear chemical resistant gloves.

Additional Precautions

Once the pump is integrated into a system (i.e. with an x-y table), a risk assessment must be completed for the combined system to determine any additional hazards that require additional guarding or protective devices.

A risk assessment in accordance with EN12100 is recommended. Isolation of personnel from the cutting area, such as light curtains and/or warning beacons should be considered.

Lockout/Tagout Procedure



This lockout/tagout procedure is designed to protect all employees from injuries caused by the unexpected energizing or startup of the machine, or the release of stored energy during service and maintenance.

This is accomplished with energy isolating devices that prevent the transmission or release of energy. An energy source is any source of electrical, mechanical, hydraulic, pneumatic, chemical, thermal, or other energy source that could cause injury to personnel.

A lockout device utilizes a lock and key to hold an energy isolating device in the safe position and prevents the machine from being energized. A tagout device is a prominent warning device that can be securely attached to the machine warning personnel not to operate the energy isolating device. This procedure requires the combination of a lockout device and a tagout device.

The lockout/tagout procedure applies to any employee who operates and/or performs service or maintenance on the machine. Before any maintenance or repairs are performed, the machine shall be isolated, and rendered inoperative as follows.

1. Shut down the machine by pressing the stop button, and open the high pressure cutting water valve to bleed the water pressure from the system.
2. Disconnect, lockout and tag the main, customer supplied, power source.
3. Lockout and tag the circuit breaker/disconnect on the electrical enclosure door.
4. Close, lockout and tag the manual shutoff valves for the supply water and air service connections.

Emergency Medical Treatment

An emergency medical card is included in the binder of this manual. This information should be used to aid in the treatment of a waterjet injury. Additional cards may be obtained by contacting KMT Waterjet Systems using the address or telephone number shown on the card.

Medical Alert

This card is to be carried by personnel working with high pressure waterjet equipment. Obtain medical treatment immediately for ANY high pressure waterjet injuries.

**KMT Waterjet Systems
635 West 12th Street
Baxter Springs, KS 66713
(620) 856-2151**

This person has been working with water jetting at pressures to 60,000 psi (374MPa, 4,137 bar, 3867 Kg/cm²) with a jet velocity of 3,000 fps (914 mps). Foreign material (sand) may have been injected with water. Unusual infections with microaerophilic organisms occurring at lower temperatures have been reported, such as gram negative pathogens as are found in sewage. Bacterial swabs and blood cultures may therefore be helpful. This injury must be treated as an acute surgical emergency and be evaluated by a qualified surgeon. Circulation may be compromised, therefore, **DO NOT APPLY HEAT TO INJURED PART**. For first aid: (1) Elevate injured part (2) Antibiotics (3) Keep injured person NPO.



1.5 Worldwide Product Support

The KMT Waterjet Customer Service Department is available to answer your questions regarding equipment installation and service. Technical assistance is available by phone and on-site support is available on request.

On-site technical assistance is available during equipment installation and startup. Additionally, technical support for service and maintenance issues and training of operators and maintenance personnel is available. Also, periodic training sessions are conducted at KMT Waterjet and customer facilities.

Contact the KMT Waterjet Customer Service Department for additional information.

USA Customer Service Department

KMT Waterjet Systems
PO Box 231
635 West 12th Street
Baxter Springs, KS 66713
USA
Phone: (800) 826-9274
Fax: (620) 856-2242
Email: wj.service@kmtwaterjet.com
Email: wj.parts@kmtwaterjet.com

Europe Technical Manager

KMT Waterjet Systems GmbH
Hohe Strasse 4-6
D-61231 Bad Nauheim
Germany
Phone: +49-6032-997-0
Fax: +49-6032-997-270
Email: order.service@kmt-waterjet.com

1.6 Spare Parts

KMT Waterjet maintains a well-stocked Spare Parts Department, staffed by trained, knowledgeable personnel. If required, emergency shipment is available. Contact the Customer Service Department to order spare parts, or for additional information.



SECTION 2

INSTALLATION

2.1 Overview



This section details equipment installation, and commissioning requirements and procedures. These procedures require a thorough understanding of the individual components and systems, safety issues, and the overall operation of the pump.

All personnel involved in the installation, operation and/or service of the pump must carefully review this manual prior to installing and commissioning the machine.

The Technical Service Department at KMT Waterjet Systems is available to assist in the installation and commissioning process. Service and repair training for maintenance personnel is also available.

2.2 Installation Summary

The following summary lists the procedures required for the installation and commissioning of the pump. A discussion of the details and requirements for each item will follow in this section.

- Upon receipt, the machine must be uncrated and moved into position on a level surface.
- Properly sized power drops with fused disconnects must be installed.
- A pneumatic drop with a manual shutoff valve and regulator for the air connection must be installed.
- Plumbing and a manual shutoff valve for the inlet supply water.
Incoming source water must meet specific water quality standards detailed in Section 7, flow rates and pressure requirements. It may be necessary to install water conditioning and/or pressure boosting equipment to meet these water purity and pressure requirements.
- Drain water plumbing must be suitably located and installed for the proper disposal of wastewater.
- High pressure tubing runs from the pump to the cutting station are installed with the appropriate mountings, support brackets and hardware.
- Wiring must be installed and connected between the pump and the cutting station control system.
- The machine must be commissioned and tested.

2.3 Installation Requirements

The pump must be installed indoors where air borne dust and contaminants are minimal. The ambient temperature should be between 45° F (7° C) and 104° F (40° C) to ensure proper operation of the pump.



Water temperatures exceeding this range will result in seal life degradation. If seal life becomes unacceptable, the addition of a chiller is recommended

Refer to Table 2-1, Equipment Dimensions and Weight, to establish a suitable installation site. A minimum clearance of 39 inches (990 mm) is required on all sides of the machine to facilitate service.

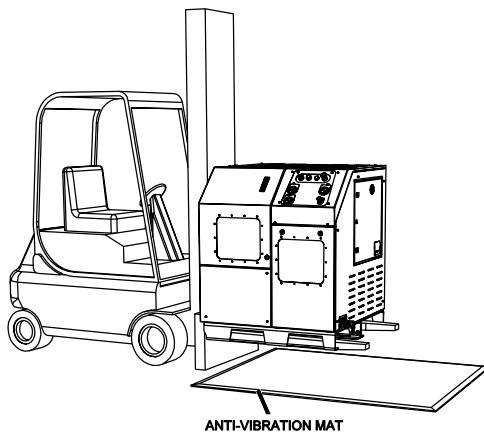

An anti-vibration mat is essential for the stability of the pump and the reduction of pump vibration. The pump should be centered on the mat with no part of the pump touching the floor beneath. With the mat placed flat on the floor, use a forklift to lower the pump onto the center of the mat.

If a pallet jack is used to locate the pump, set the anti-vibration mat in place and roll the pump over the mat and into position. Properly positioning the pump may require two people.

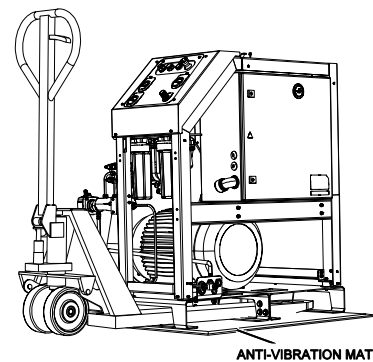

Do not trim the mat or bolt the pump to the floor through the mat material.

Figure 2-1: Equipment Dimensions

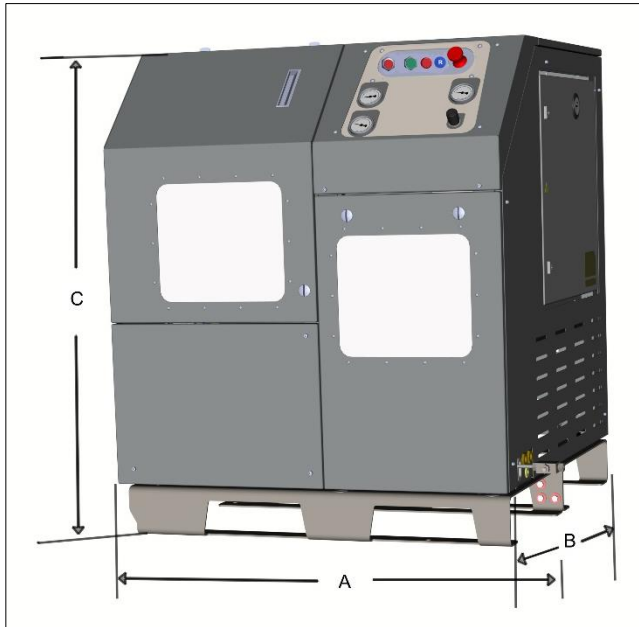

Table 2-1
Equipment Dimensions

Horsepower	Length (A)	Width (B)	Height (C)	Weight
30 HP	41.0" (1041 mm)	43.0" (1092 mm)	50.0" (1270 mm)	1125 lbs (510 Kg)

Transporting

The weight of the machine is not evenly distributed from one end to the other. The machine can be safely lifted from either end or either side. Lifting from the front or rear with a pallet jack is the best means of transport.

When the machine is removed from the crate, note the position of the fork pockets on the bottom of the machine. The pockets are positioned in relationship to the center of gravity to balance the weight on the pallet jack or forklift.

2.4 Power Requirements

Power supplied to the pump, including overload protection, and wiring for remote control must comply with local, regional and national electrical codes. Service voltage and ampacity must meet the requirements of the specific model. Voltage fluctuations in excess of +/- 10 percent of nominal voltage may damage the machine and void the warranty.

NOTE

Refer to the nameplate for machine specific ampacity and power voltage requirements.

2.5 Service Connections

The pump requires an incoming water source, a drain line, a high pressure discharge line and an air supply line.



Thoroughly purge all supply plumbing prior to connection to remove any residue that could contaminate the system.

All service connections are made on the bulkhead of the machine as shown in Figure 2-2, Service Connections. All piping must comply with local, regional and national codes.

Manual shutoff valves should be installed for the supply water and air connections. To facilitate service, the valves should be located as close as practical to the interface connection.

Figure 2-2: Service Connections

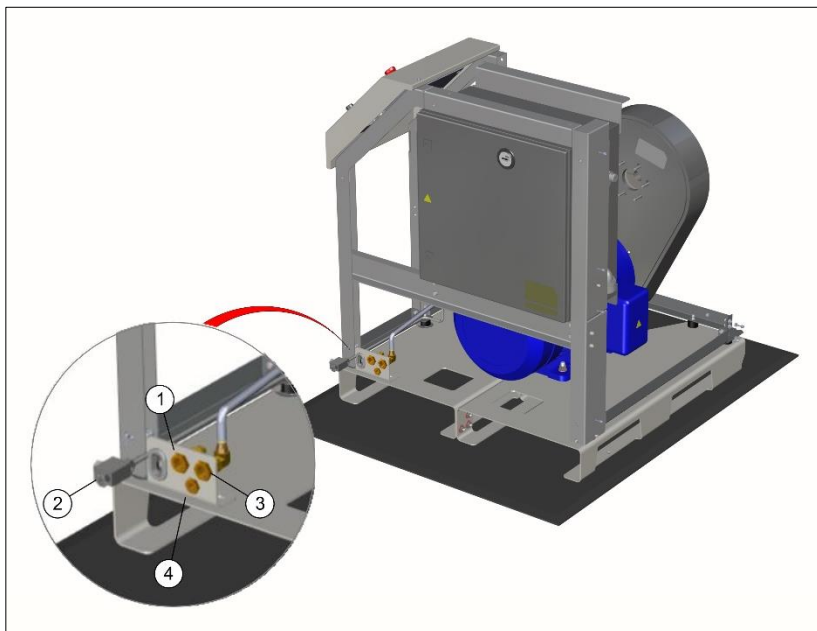





Table 2-2
Service Connections

			Connection
1		Supply water in	1/2" NPT
2		HP cutting water out	3/8" HP
3		Drain	1/2" NPT
4		Air in	1/4" NPT

Inlet Water Requirements

The supply water must meet the minimum water quality standards outlined in Section 7, Specifications. Poor water quality will drastically shorten component life and void the warranty.

Supply water piping must be sized for 150% of the pump capacity and should match the intended maximum duty cycle.

The inlet water must be maintained at a temperature between 55 and 70° F (12.7 and 21° C) for proper pump performance. Premature component failure is common if water temperatures are outside this range. Inlet water chillers should be used if the inlet water temperature is above this range.

Only PVC, copper or rubber hoses should be used between the inlet water source and the machine.

Drain

Cutting water is discharged from the pressure control valve through the drain port. The discharge is considered wastewater and must be piped to an appropriate location, i.e. a sewer line.

High pressure plumbing is not required; however, piping must comply with local, regional and national codes. The discharged water is extremely hot, with temperatures in excess of 150° F (66° C).



To ensure the pressure control valve does not suffer damage due to siphoned catcher tank water, connect the valve drain line directly to an outlet drain above the water line, or suspend the line above the catcher tank water level.

Plant Air

The facility compressed air connection should provide clean, dry air between 90 and 120 psi (6.2 and 8.3 bar). The manual air regulator should be adjusted and set at the point where 55,000 psi (3,792 bar) water pressure is achieved with the orifice installed and the nozzle open.

The following table provides specifications for each ISO air quality classification. KMT recommends adherence to Quality Class 4.

Table 2-3
ISO Air Quality Classifications

ISO Quality Class	Maximum Particle Size (microns)	Maximum Pressure Dew Point (water @ 100 psi)	Maximum Oil Content (Mg/m ³)
1	0.1	-94° F (-60° C)	0.01
2	1	-40° F (-40° C)	0.1
3	5	-4° F (-20° C)	1
4	15	+38° F (+3° C)	5
5	40	+45° F (+7° C)	25
6	--	+50° F (+10° C)	--

2.6 High Pressure Piping

High pressure piping is used to transport high pressure cutting water from the machine to the cutting station. High pressure piping and fittings must be properly rated and sized. When transporting high pressure water over long distances, tubing and fittings with an outside diameter of 9/16-inch are recommended. The large tubing size reduces vibration, strain and motion; as well as reducing pressure drop and pulsation.



High pressure tubing and fittings must be rated for 60,000 psi (4,137 bar). Failure to use properly rated components may result in component failure causing equipment damage, personal injury or death.

High pressure tubing lengths are coned and threaded prior to installation. KMT Waterjet provides both hand and power tools for coning and threading high pressure tubing. See Table 2-4, Power Coning and Threading Tools, for descriptions and part numbers.

Table 2-4
Power Coning and Threading Tools

	Part Number
1/4" Coning Tool	05109897
3/8" Coning Tool	05109889
9/16" Coning Tool	05109871
1/4" Threading Tool	05122742
3/8" Threading Tool	05120258
9/16" Threading Tool	05122759
1/4" Tube Vise	05108782
3/8" Tube Vise	05108790
9/16" Tube Vise	05108774

Measurements and Dimensions

Tubing must be cut to the proper length, both ends of the tubing must then be coned, threaded and deburred.

To determine the tube length, measure the distance between the fittings, and add two times the engagement allowance shown in Table 2-5. Table 2-6 lists the required cone and thread dimensions illustrated in Figure 2-4.

Table 2-5
Engagement Allowance (EA)

1/4" Tubing	0.49" (12.4 mm)
3/8" Tubing	0.68" (17.3 mm)
9/16" Tubing	0.86" (21.8 mm)

Figure 2-3: Tube Length

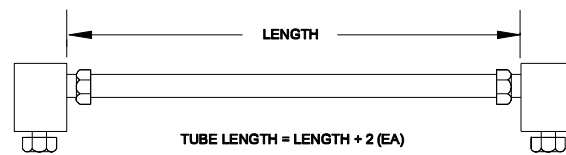

Figure 2-4: Cone and Thread Dimensions

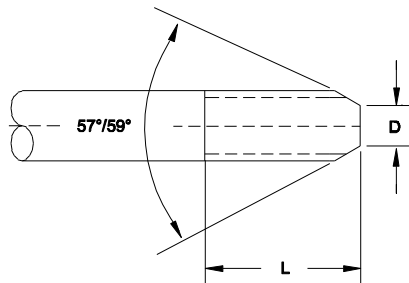

Table 2-6
Cone and Thread Dimensions

Tube OD	Tube ID	D (Maximum)	L (Maximum)	Thread UNF-LH
1/4" (6.35 mm)	0.083" (2.11 mm)	0.125" (3.2 mm)	0.562" (14.3 mm)	1/4" - 28
3/8" (9.52 mm)	0.125" (3.18 mm)	0.219" (5.6 mm)	0.750" (19.1 mm)	3/8" - 24
9/16" (14.29 mm)	0.188" (4.78 mm)	0.281" (7.1 mm)	0.938" (23.8 mm)	9/16" - 18

Power Coning

1. Secure the tubing in a tube vise. No more than the recommended length of tubing should extend beyond the face of the vice. See Table 2-7, Recommended Extension Length.
2. Mount the coning tool in a 3/8-inch or 1/2-inch, variable speed power drill. Apply cutting oil to the end of the tube and slide the coning tool on the tubing.
3. While the cone is being cut, apply steady pressure against the end of the tubing.
4. Apply cutting oil frequently and liberally throughout the cutting operation. Medium weight cutting oil with high sulfur content is recommended.
5. The tool will stop cutting when the tube angle and facing is complete.



NOTE

Clean the machining chips from the blade and body of the tool before coning the next tube.

Table 2-7
Recommended Extension Length

1/4" Tubing	1.25-1.50" (31.8-38.1 mm)
3/8" Tubing	1.25-1.50" (31.8-38.1 mm)
9/16" Tubing	1.75-2.00" (44.5-50.8 mm)

Power Threading

1. Secure the coned tubing in a tube vise. No more than the recommended length of tubing should extend beyond the face of the vice. See Table 2-7, Recommended Extension Length.
2. Mount the threading tool in a 3/8-inch or 1/2-inch, variable speed power drill. Apply cutting oil to the end of the tube and slide the threading tool on the tubing.
3. Make sure the drill is set to turn counter-clockwise. Apply steady pressure against the end of the tubing while the threads are being cut.
4. Apply cutting oil frequently and liberally throughout the cutting operation. Medium weight cutting oil with high sulfur content is recommended.
5. Continue threading until the proper thread length is achieved, see Table 2-6, Column L. Reverse the direction of the drill and remove the threading tool.

NOTE

Clean the machining chips from the die and body of the tool before threading the next tube.

2.7 High Pressure Connections

When installing high pressure discharge piping it is essential that all burrs are carefully removed and the tubing sections purged with clean compressed air prior to assembly. Lightly spraying the inside of the tube with a carrier fluid, such as WD-40, before purging with air will help carry the burrs.

High pressure piping must be installed without torsional or bending stresses and proper supports and guides must be provided. Torsional stress will cause premature component failure.

Pure Goop anti-seize compound must be applied to the threads and contact surfaces of all stainless steel components prior to assembly. Failure to lubricate components with Pure Goop will result in galling, rendering the components useless.



Do not use any other anti-seize compound. Apply Pure Goop **only to stainless steel** components.

Standard Connections

Use standard connections for general applications where internal pressure is the only load on the tubing.

1. Deburr the tubing ID and thoroughly clean the tubing threads.
2. Slip the gland nut onto the tubing.
3. Apply Pure Goop to the threads on the tubing. Screw the collar onto the threaded end of the tubing leaving 1-1/2 to 2-1/2 threads exposed on the tubing between the collar and the coned tubing.

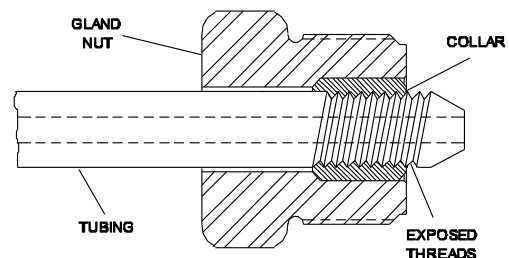

4. Apply Pure Goop to the male threads on the gland nut and insert the tubing into the connection. Engage the gland nut and tighten finger tight.
5. Tighten the gland nut to the torque specifications in Table 2-8.



Proper piping supports and guides must be provided. End connections will not support the tubing load alone.

Anti-Vibration Connections

The bending stresses resulting from excessive vibration or shock on the threaded area of the tubing can cause premature failure at the back of the thread. Anti-vibration connections must be used when tubing will be subjected to vibration, rotation and movement.

The anti-vibration collet gland transfers the stress to the unthreaded section of the tubing, and the gripping action of the collet strengthens the entire assembly.

1. Deburr the tubing ID and thoroughly clean the tubing threads.
2. Slip the gland nut and the collet onto the tubing.
3. Apply Pure Goop to the threads on the tubing. Screw the collar onto the threaded end of the tubing leaving 1-1/2 to 2-1/2 threads exposed on the tubing between the collar and the coned tubing.
4. Apply Pure Goop to the male threads on the gland nut and insert the tubing into the connection. Engage the gland nut and tighten finger tight.

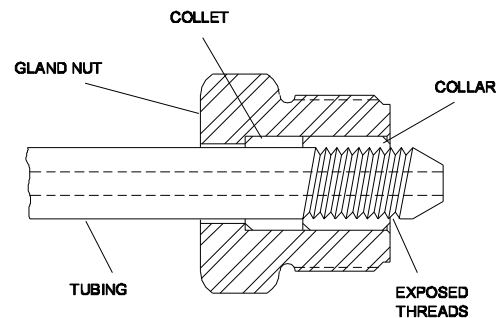

5. Tighten the gland nut to the torque specifications in Table 2-8.

When a flexible whip is used to allow cutting nozzle movement, anti-vibration fittings and proper supports and guides must be provided to prevent failures from non-water related stresses. The whip will only flex in a single plane without being subjected to torsional stress. The use of high pressure swivels is strongly recommended.

Table 2-8
Torque Specifications
High Pressure Connections

1/4" Tubing	25 ft-lb (34 Nm)
3/8" Tubing	50 ft-lb (68 Nm)
9/16" Tubing	110 ft-lb (149 Nm)

2.8 Commissioning

When the machine has been positioned, all service connections installed, and the high pressure plumbing has been installed to the cutting area, the machine is ready to be commissioned.

The following procedure is used for the initial startup and testing of the machine.

1. Check all areas in and around the pump for foreign objects and debris. Remove all tools, parts, etc. from the area.
2. Fill the crankcase to the fill mark with a recommended oil. See Section 7, Specifications, for a list of recommended oils.



Never operate the pump without oil or with dirty oil. This can cause extensive damage and is not covered by warranty.

3. Open the shutoff valves on the service connections and check for leaks.
4. Make sure the belt guard is attached.
5. Check the connection between the main power disconnect and the disconnect/circuit breaker on the enclosure door. Verify the proper voltage supply. Close the enclosure door and place the electrical disconnect in the on position.
6. Check the motor rotation. The correct rotation is clockwise when viewed from the pulley. If the motor shaft is rotating in the wrong direction, the electrical power phase must be reversed to any two motor leads. The leads can be reversed at the disconnect/circuit breaker on the enclosure door, or at the main power disconnect.



Do not allow the motor to run backward. Incorrect motor rotation will result in damage to the pump.

7. Release the emergency stop button.
8. Turn the manual air pressure regulator all the way counter-clockwise, reducing the air pressure to zero.
9. Depress the red, pressure relief buttons on both water filters to release trapped air.
10. Turn the pump on by pressing the start button.
11. When the pump is spinning at full rpm, turn the air pressure regulator clockwise until the pressure display reads 55,000 psi (3,792 bar).
12. Operate the pump at full pressure for 5-10 minutes.



13. Check for any leaks in the plumbing, or around the high pressure cylinders. If leaks are detected, stop the machine and correct any problems.
14. The pump is now ready for use.

2.9 Decommissioning

When the TRILINE™ pump is decommissioned and taken out of service for any reason all local regulations must be adhered to.

All utilities must be de-energized and disconnected. All high pressure and low pressure water must be expelled from the pump if the pump is exposed to the potential of freezing temperatures.

If the unit is to be disposed of, all local codes must be observed. KMT Waterjet recommends recycling the unit. Most of the heavy metallic content of the unit can be recycled. Contact KMT if assistance is required in identifying materials.



SECTION 3

MAINTENANCE

3.1 Overview

Systems fail gradually; seals and connections begin to leak slowly or suddenly through specially designed weep holes. Water or oil dripping from a weep hole indicates internal seals or valves are beginning to fail, a warning that maintenance will be required.

3.2 Maintenance

In order to keep the equipment in optimum operating condition, routine and preventive maintenance is essential, see Table 3-1, Mandatory Maintenance Schedule.

Detailed maintenance and troubleshooting procedures for specific systems are provided in Sections 5 of this manual.

Daily Inspection

The following inspection procedures should be performed each shift. If problems are detected, they should be remedied before placing the machine in service.

- Prior to startup, inspect the area around the machine, the high pressure piping and connections for indications of leaks.
 - Make sure there is no maintenance work in process.
 - Check the oil level.
- As the machine is started and water pressure increases, listen for unusual sounds.
 - Check for water leakage.
 - Check the condition of the water filter.

Periodic Maintenance

A number of factors can contribute to component failure; poor water quality, operating conditions, or improper maintenance procedures. Maintaining a service log can be a useful method of tracking component life and maintenance trends. Analyzing service intervals will assist in preparing a preventive maintenance schedule tailored to your specific application and production requirements. Periodic maintenance, at regularly scheduled intervals, will minimize unscheduled downtime and premature component failure.

Improper assembly can lead to the premature failure of components. Follow maintenance procedures carefully; properly clean components prior to assembly and tightened to the correct torque specifications.

- Maintain a clean, dust and dirt free work area for maintenance.
- Clean water leaks or spills to prevent slick surfaces.
- Use only clean, dry air and clean, filtered solvent when flushing parts.
- Use lint free cloths for cleaning.

- Use extreme care when aligning close tolerance parts for assembly. Do not force the parts together. If parts bind during assembly, they must be disassembled and realigned.
- Use only original KMT Waterjet replacement parts for consistent performance and reliability; and to protect equipment warranty.



To avoid unsafe conditions and the risk of equipment damage, operating personnel and service technicians must carefully read and follow the procedures in this manual.



Mandatory Maintenance Schedule

Table 3-1
Mandatory Maintenance Schedule

500 Hours Minor Kit	1,000 Hours Minor Kit	1,500 Hours Major Kit	2,000 Hours Minor Kit	2,500 Hours Minor Kit	3,000 Hours Major Kit PCV Kit	3,500 Hours Minor Kit	4,000 Hours Minor Kit	4,500 Hours Major Kit	5,000 Hours Minor Kit
Replace dynamic seal and rod seal	Replace dynamic seal and rod seal	Replace dynamic seal, rod seal and seal carrier	Replace dynamic seal and rod seal	Replace dynamic seal and rod seal	Replace dynamic seal, rod seal and seal carrier	Replace dynamic seal and rod seal	Replace dynamic seal and rod seal	Replace dynamic seal, rod seal and seal carrier	Replace dynamic seal and rod seal
Lap check valve body	Lap check valve body	Replace all discharge check valve components, including the valve body	Lap check valve body	Lap check valve body	Replace all discharge check valve components, including the valve body	Lap check valve body	Lap check valve body	Replace all discharge check valve components, including the valve body	Lap check valve body
Replace discharge check valve poppet, seat, spring and guide	Replace discharge check valve poppet, seat, spring and guide	Replace inlet check valve poppet, spring, sleeve and dynamic seal spring	Replace discharge check valve poppet, seat, spring and guide	Replace discharge check valve poppet, seat, spring and guide	Replace inlet check valve poppet, spring, sleeve and dynamic seal spring	Replace discharge check valve poppet, seat, spring and guide	Replace discharge check valve poppet, seat, spring and guide	Replace inlet check valve poppet, spring, sleeve and dynamic seal spring	Replace discharge check valve poppet, seat, spring and guide
Replace end cap o-ring	Replace end cap o-ring	Replace end cap o-ring	Replace end cap o-ring	Replace end cap o-ring	Replace end cap o-ring	Replace end cap o-ring	Replace end cap o-ring	Replace end cap o-ring	Replace end cap o-ring
Replace inlet check valve poppet, spring and sleeve	Replace inlet check valve poppet, spring and sleeve	Replace plunger and plunger spring	Replace inlet check valve poppet, spring and sleeve	Replace inlet check valve poppet, spring and sleeve	Replace plunger and plunger spring	Replace inlet check valve poppet, spring and sleeve	Replace inlet check valve poppet, spring and sleeve	Replace plunger and plunger spring	Replace inlet check valve poppet, spring and sleeve
Replace HP cylinder o-ring	Replace HP cylinder o-ring	Replace HP cylinder and o-ring	Replace HP cylinder o-ring	Replace HP cylinder o-ring	Replace HP cylinder and o-ring	Replace HP cylinder o-ring	Replace HP cylinder o-ring	Replace HP cylinder and o-ring	Replace HP cylinder o-ring



Table 3-1
Mandatory Maintenance Schedule

500 Hours Minor Kit	1,000 Hours Minor Kit	1,500 Hours Major Kit	2,000 Hours Minor Kit	2,500 Hours Minor Kit	3,000 Hours Major Kit PCV Kit	3,500 Hours Minor Kit	4,000 Hours Minor Kit	4,500 Hours Major Kit	5,000 Hours Minor Kit
Replace subplate adapter o-rings, rod seal and retaining ring	Replace subplate adapter o-rings, rod seal and retaining ring	Replace subplate adapter o-rings, rod seal and retaining ring	Replace subplate adapter o-rings, rod seal and retaining ring	Replace subplate adapter o-rings, rod seal and retaining ring	Replace subplate adapter o-rings, rod seal and retaining ring	Replace subplate adapter o-rings, rod seal and retaining ring	Replace subplate adapter o-rings, rod seal and retaining ring	Replace subplate adapter o-rings, rod seal and retaining ring	Replace subplate adapter o-rings, rod seal and retaining ring
Replace PCV poppet, seat and static seal ring	Replace PCV poppet, seat and static seal ring	Replace PCV poppet, seat and static seal ring	Replace PCV poppet, seat and static seal ring	Replace PCV poppet, seat and static seal ring	Replace PCV poppet, seat and static seal ring	Replace PCV poppet, seat and static seal ring	Replace PCV poppet, seat and static seal ring	Replace PCV poppet, seat and static seal ring	Replace PCV poppet, seat and static seal ring
Replace crankcase oil	Replace crankcase oil	Replace crankcase oil	Replace crankcase oil	Replace crankcase oil	Replace PCV plunger and plunger seal	Replace crankcase oil	Replace crankcase oil	Replace crankcase oil	Replace crankcase oil
		Replace belts			Replace PCV bearing assembly			Replace belts	
					Replace PCV o-rings				
					Replace crankcase oil				
					Replace belts				

High Pressure System Maintenance

The high pressure system components are readily accessible, and can easily be removed from the unit for maintenance and service.



High pressure fittings, valves and tubing must be rated for 60,000 psi (4,137 bar). Failure to use properly rated components may result in component failure, equipment damage and personal injury.

- Do not over-torque fittings to stop leakage.
- Ensure all components are clean, free of burrs, metal particles, dirt and dust prior to assembly.

After servicing high pressure components the high pressure water system must be thoroughly flushed to remove any debris or contaminants.

1. Operate the pump for a short period with the nozzle valve open and a large orifice installed.
2. Increase the operating pressure in gradual increments. Check all high pressure connections for leaks.

Many components are lubricated prior to assembly. Table 3-2 lists the recommended lubricants and their applications. Substitutions are not recommended.

Table 3-2
Lubrication Specifications

Description	Application	Part Number
Pure Goop, 1 ounce	Stainless steel threads and metal-to-metal joints	10084440
FML-2 Grease, 14-1/2 ounce	O-rings, backup rings, bearing rings, seal components	10087385
JL-M Grease, 16 ounce	Non-stainless steel threads	49832199

3.3 Maintenance Precautions

Make sure all safety devices are operational. Check each device on a specified schedule. If the device does not function, replace it before operating the machine.

Check the EMERGENCY STOP button. The normal operating position is pulled out. Turn the power on and activate the emergency stop button by pushing it in to verify the power goes off and high pressure is bled from the system.



Before performing any maintenance on the equipment, take the system out of service and make sure the controls are properly locked and marked. Never perform any maintenance on the equipment without making sure the main control power is locked out in the OFF position.

- **Never** service or maintain the equipment while it is operating.
- Steam or fog inside the cover is an indication of a high pressure leak.

All high pressure leaks must be repaired immediately. Press the EMERGENCY STOP button to turn the control power off and bleed off the high pressure water from the pump **before** lifting the cover.

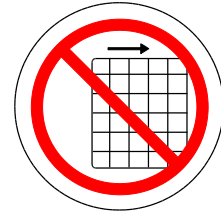

- Never service or maintain any high pressure component, or loosen any high pressure fitting when it is pressurized.

Press the EMERGENCY STOP button to turn the control power off and bleed off the high pressure water from the pump before servicing.

- If leakage occurs at a sealing surface, high pressure water is released through weep holes.

If a pressurized fitting is loosened, a jet of high pressure water will exit the nearest weep hole with **possible hazardous results**.





SECTION 4 OPERATION

4.1 Overview

The operator interface is through a manually adjustable display panel.

Figure 4-1: Standard Display

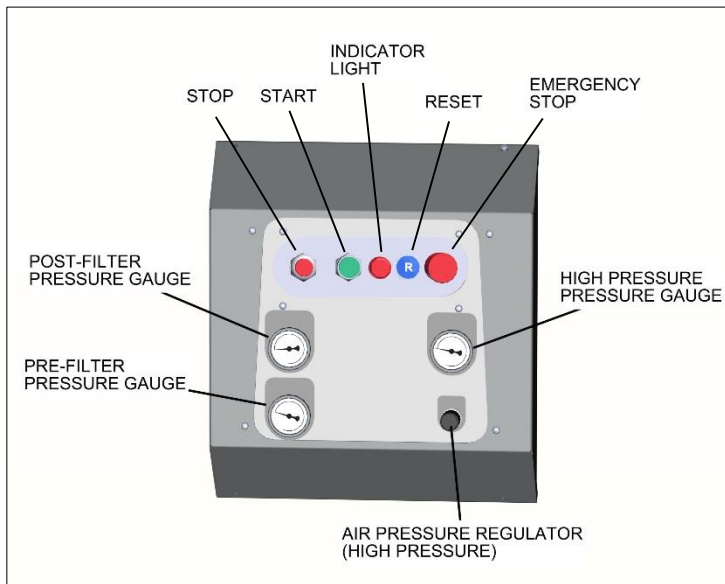

**Table 4-1
Display Labels**





	<p>Inlet Water Pressure (pre-filter) Indicates water pressure before the inlet water has passed through the water filters</p>
	<p>Inlet Water Pressure (post-filter) Indicates water pressure after the inlet water has passed through both water filters</p>
	<p>High Air Pressure Indicates the air pressure supplied to the pressure control valve as controlled by the regulator below the gauge</p>
	<p>Low Air Pressure On dual pressure units, indicates the minimum air pressure setting</p>

Figure 4-2: Display with Optional Dual Pressure



Control is changed from the local panel to remote controls using the keyed switch on the electrical enclosure.

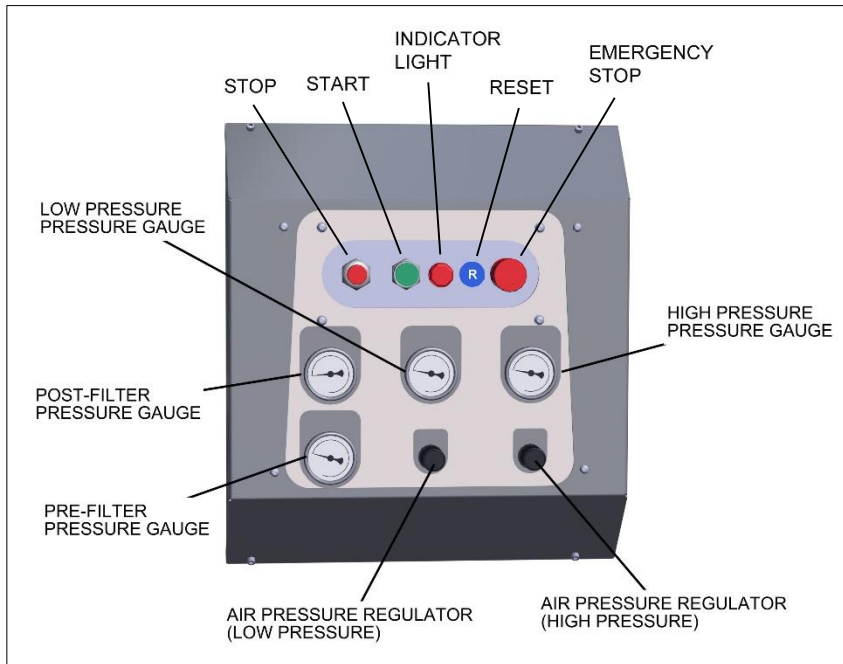

4.2 Preparing the Pump for Startup

- After initial installation
- Before the beginning of each shift
- After the installation of on the maintenance kits

Follow this procedure to ensure the pump if ready for operation.

1. Flush debris from all water supply lines before connecting them to the pump.



Debris in the water supply line can cause extensive damage to high pressure components.

2. Fill the pump case with the recommended oil. Fill the oil reservoir to the fill mark.



Never operate the pump without oil or with dirty oil. This can cause extensive damage to high pressure components.

3. Ensure water, air and drain lines are correctly routed and connected.



The cutting head must be installed when operating the pump.

4. Clear tools, parts and rags from around the pump. Check in and around the pump for foreign objects and debris.
5. Open the customer-supplied inlet water, air and discharge water valves and check all connections for leaks.



Do not tighten any loose or leaking connections while the pump is operating or while the line is pressurized.

6. Make sure the belt guard is attached.
7. Place the main electrical disconnect in the on position.
8. Release the emergency stop button(s).

4.3 Starting the Pump

Follow this procedure at initial startup of a shift.

1. Check all connections for leaks.
2. Turn the air pressure regulator all the way counter-clockwise, reducing the air pressure to zero.
3. Depress the red pressure relief buttons on both inlet water filters to release trapped air.
4. Press the start button to turn the pump on. When the pump is spinning at full rpm, turn the air pressure regulator clockwise until the pressure display reads 55,000 psi (3,792 bar).

5. Operate the pump at full pressure for 5-10 minutes while checking for leaks. If leaks are detected, stop the pump and observe the Lockout out/Tagout procedure before tightening any loose or leaking connections.



Do not tighten any loose or leaking connections while the pump is operating or while the line is pressurized.

6. The pump is now ready for service.



SECTION 5

SERVICE PROCEDURES

5.1 Overview

Procedures for installing mandatory maintenance kits as well as the replacement of worn parts that have reached the end of their life are included in this section. Follow the service guidelines listed below to achieve optimum performance and component life,

- Read and thoroughly understand each maintenance procedure before starting the work.
- Do not substitute fluids, sealants or lubricants specified in the procedures.
- Handle critical parts with care and avoid scratching or denting high pressure components.



NOTE

A blue rectangular box with a black border and the word 'NOTE' in white, bold, uppercase letters.

All components containing high pressure water are susceptible to stress fatigue accelerated by nicks, scratches or other surface disruptions. Replace damaged components.

- Protect all machined and lapped mating surfaces against nicks, scratches and burrs.
- Keeping components clean is critical. Airborne dirt and abrasive have serious detrimental effects on part life.
- Clean and blow compressed air on parts being reassembled. Clean all parts with fresh, clean solvent that does not leave a residue, such as isopropyl alcohol.

Life expectancy of high pressure seals and other high pressure components is related to stress on the part, and is a function of stroke rate, water pressure and inlet water temperature. Exceeding pump ratings can lead to increased costs and downtime.

Figure 5-1: High Pressure System Components

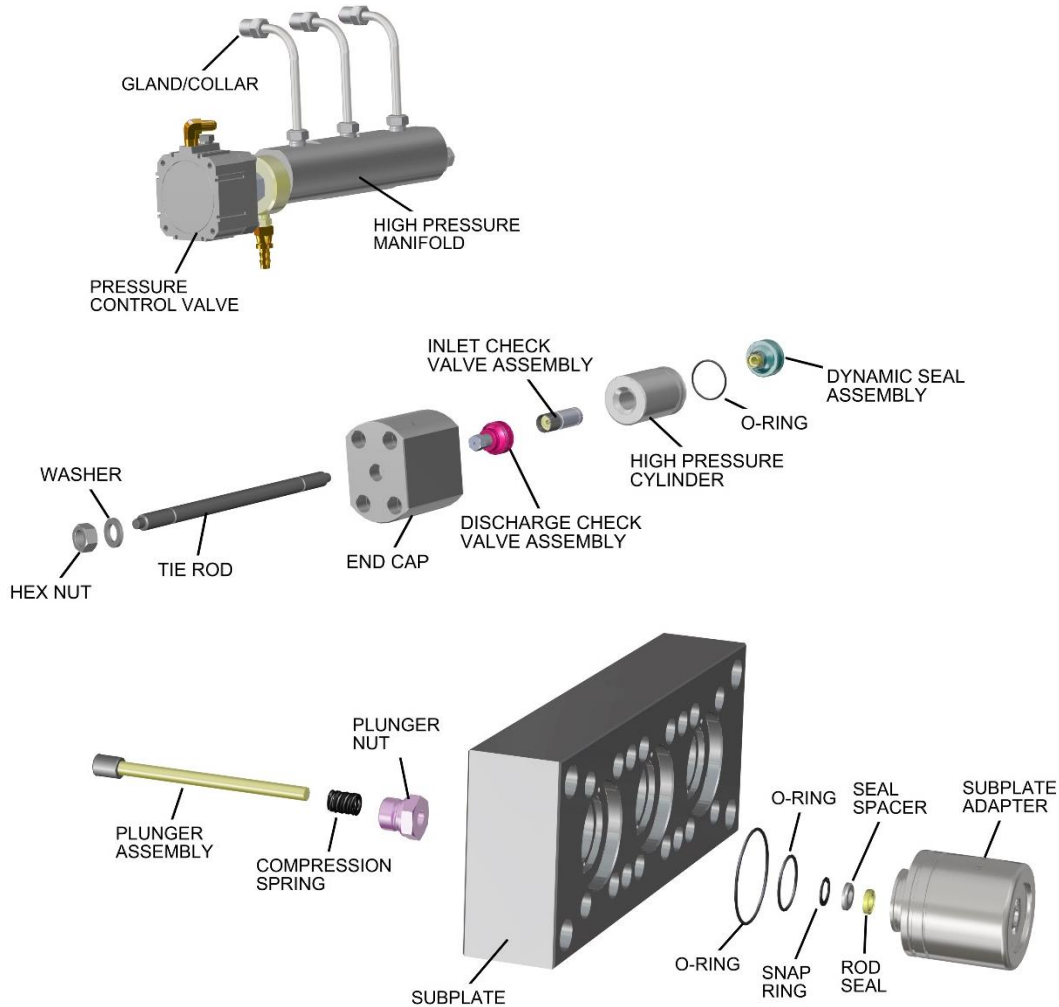

5.2 Service and Maintenance Overview

Never perform any type of maintenance on the pump while it is pressurized. Always turn the power off and bleed the high pressure water before servicing. Pressing the emergency stop button turns the control power off to the pump, and bleeds high pressure water through the drain.

Improper assembly can lead to the premature failure of components. Follow maintenance procedures carefully; components must be properly cleaned prior to assembly and tightened to the correct torque specifications.



Specialized Maintenance Tools

Specialized tools have been designed to facilitate pump maintenance and are supplied with the pump. These tools, and their respective part numbers are listed in Table 5-1, Specialized Maintenance Tools.

Table 5-1
Specialized Maintenance Tools
Kit 72185375

Plunger nut tool	72185393
Rebuild clamp (check valve body)	72185400
Belt tension gauge	72185408
Glass pane	10149052
Pure Goop	72185416
Medical alert card	05048681
Hex head screw	49881485
Flat washer	95277109
Oil seal installation tool, 22.70 x 65MM	80101403
Oil seal installation tool, 40MM x 28MM	80101395

Mandatory Maintenance Schedule

At fixed intervals for the life of the pump, you must perform a mandatory maintenance kit installation. See Section 3, Table 3-1, Mandatory Maintenance Schedule.

Mandatory maintenance is designed to help minimize unscheduled downtime and premature parts failure. Maintaining a service record is recommended to help prepare a maintenance schedule compatible with your application and requirements.

If service is required outside of the maintenance schedule, record the actual hour meter reading for the installation. The next scheduled maintenance should take place at the specified number of hours from this reading.

5.3 High and Low Pressure Connections

Before performing any maintenance on the high pressure components, it is necessary to remove the high and low pressure water piping and air connection. Use the following procedure to remove and install the piping.



Severe injury can result if the machine is not properly locked out. Observe electrical Lockout/Tagout procedures before performing maintenance.

Ensure all pressure is relieved or blocked from the high pressure circuits before performing maintenance.



1. Turn the inlet supply water and the air supply off.

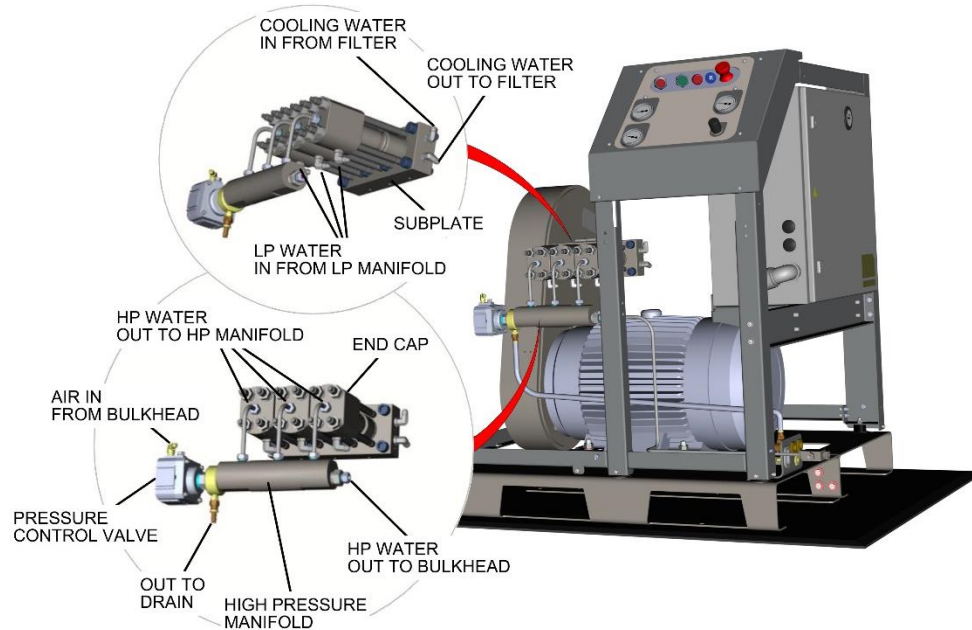

2. Loosen and remove the high pressure connection from the high pressure manifold.
3. Remove the air and drain connections from the pressure control valve.
4. Loosen and remove high pressure tubing and anti-vibration connections from the end caps and the high pressure manifold. Place the manifold and pressure control valve assembly aside.

NOTE

If maintenance will require removing the subplate, remove the cooling water connections on the subplate.

5. When the required maintenance has been completed and the components reassembled, install the high pressure tubing and anti-vibration connections from the end caps to the high pressure manifold. Apply Pure Goop to the threads on the high pressure gland fittings. Before installing the high pressure fittings, ensure proper collar position, 1-1/2 to 2-1/2 threads should be exposed. Install and tighten the fitting to the torque specifications in Table 5-1.
6. Install the high pressure connection on the high pressure manifold.
7. Install the air and drain connections on the pressure control valve.
8. Turn the inlet supply water and the air supply on and check for low pressure leaks.

**Table 5-2
Torque Specifications
High Pressure Fittings**

1/4-inch HP Gland Nut	25 ft-lbs (34 Nm)
3/8-inch HP Gland Nut	50 ft-lbs (68 Nm)
9/16-inch HP Gland Nut	110 ft-lbs (149 Nm)

5.4 Loading and Unloading the Tie Rods

The pressure loading tool is used to accurately load and unload the tie rods. Adherence to the following procedures is vital to prevent damage to the tie rods, high pressure seals or cylinders.

Figure 5-2: Pressure Loading Tool

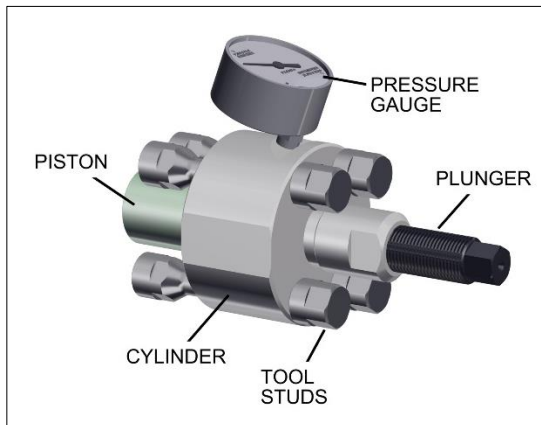



Do not attempt to tighten the tie rod nuts using a torque wrench. No other methods than those described in this section may be used to load the tie rods.

Unloading the Tie Rods

1. Ensure the loading tool is clean and free of leaks or damage.
2. Rotate the tool plunger counter-clockwise until it stops to ensure it is fully retracted.



Rotate the tool plunger **by hand only** to prevent damage to the tool.

3. Ensure the tie rods are clean and free of debris.

Figure 5-3: Unloading the Tie Rods

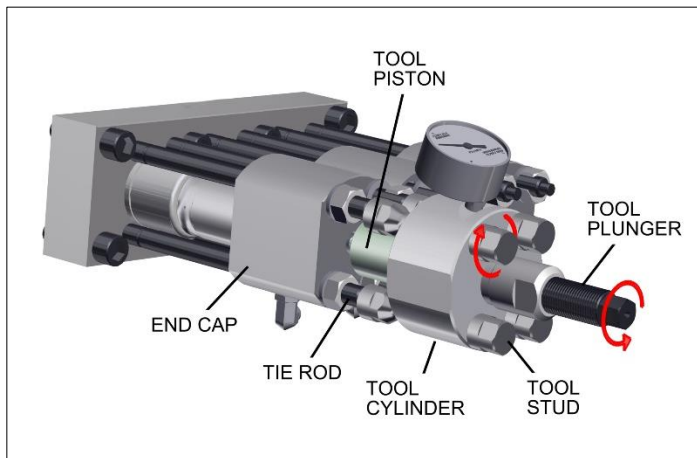

4. While supporting the tool, hand-tighten the tool studs to thread the tool onto the end of the tie rods.



Alternate between opposite studs to bring the tool in evenly and prevent binding.

5. Tighten the tool studs firmly to seat the tool piston fully into the tool cylinder and against the end cap.



Do not use any type of impact tool.

6. Verify the tool plunger is seated firmly against the stop.



The tool plunger must be seated against the stop in order to fully seat the tool piston within the tool cylinder.

7. Before proceeding, turn each of the tool studs counter-clockwise 3/4 turn.



Failure to back the tool studs out 3/4 turn could make tool removal difficult and possibly result in damage.

8. Use a 3/4-inch (19 mm) socket and ratchet to rotate the tool plunger clockwise until a gauge pressure of 21,750 psi (1,500 bar) is achieved.
9. Loosen the end cap, hex nuts two full turns. Use a 15/16-inch (24 mm) combination wrench if necessary.



Do not back them against the tool studs or they will seize together when pressure is removed from the tool.

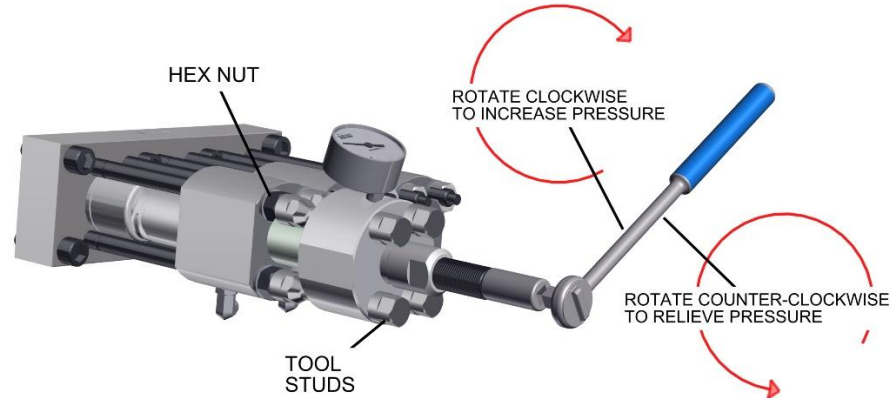

10. Use the 3/4-inch (19 mm) socket and ratchet to rotate the tool plunger counter-clockwise until the pressure is relieved and the gauge reads 0 psi (0 bar). Continue to rotate the plunger until it is fully retracted and against the stop.
11. Support the tool, loosen and remove the tool studs from the tie rods. During removal alternate between opposite sides to avoid binding.
12. Remove the hex nuts and washers from the tie rods to access the high pressure components.
13. Repeat this procedure for the remaining cylinders.
14. Clean the loading tool and inspect it for leaks or damage and repair it if necessary.

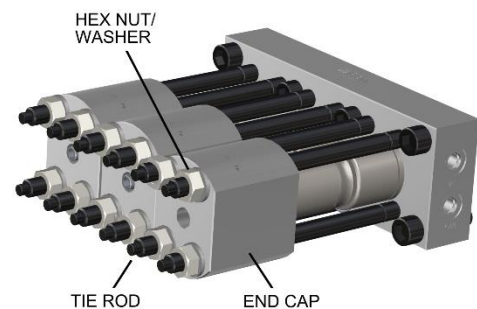

Loading the Tie Rods

When maintenance on the high pressure components is completed, the pressure loading tool is used to load the tie rods.

1. Apply JL-M anti-seize to both sides of the washers and position the washers over the tie rods.
2. Hold the end cap assembly to ensure the springs are compressed and tighten the hex nuts on the tie rods.
3. Ensure the loading tool is clean and free of leaks or damage.
4. Rotate the tool plunger counter-clockwise until it stops to ensure it is fully retracted.
5. Ensure the tie rods are clean and free of debris.

Figure 5-4: Loading the Tie Rods

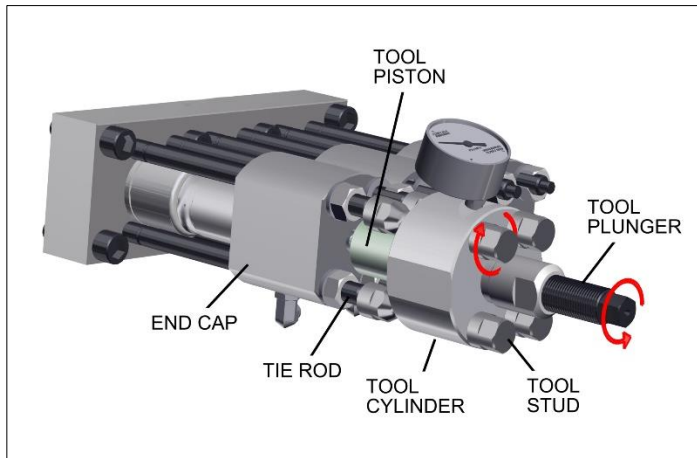

6. While supporting the tool, hand-tighten the tool studs to thread the tool onto the end of the tie rods.

NOTE

Alternate between opposite studs to bring the tool in evenly and prevent binding.

7. Tighten the tool studs firmly to seat the tool piston fully into the tool cylinder and against the end cap.
8. Verify the tool plunger is seated firmly against the stop.

NOTE

The tool plunger must be seated against the stop in order to fully seat the tool piston within the tool cylinder.

9. Use a 3/4-inch (19 mm) socket and ratchet to rotate the tool plunger clockwise until a gauge pressure of 21,750 psi (1,500 bar) is achieved.
10. Tighten the hex nuts by hand until they are firmly seated against the end cap. The nuts must be fully bottomed out against the washers and end cap.

NOTE

Do not use wrenches when tightening the hex nuts.



11. Use the 3/4-inch (19 mm) socket and ratchet to rotate the tool plunger counter-clockwise until the pressure is relieved and the gauge reads 0 psi (0 bar). Continue to rotate the plunger until it is fully retracted and against the stop.
12. Support the tool, loosen and remove the tool studs from the tie rods. During removal alternate between opposite sides to avoid binding.
13. Repeat this procedure for the remaining cylinders.
14. Clean the loading tool and inspect it for leaks or damage and repair it if necessary.



5.5 Minor Maintenance Kit

The minor maintenance kit must be installed every 500 hours. Use the following procedure to install the minor maintenance kit. The minor maintenance kit contains the following replacement components.

Table 5-3
Minor Maintenance Kit
72185099

Part Number	Component	Subassembly
72185117	Dynamic seal	Dynamic Seal Assembly
72185125	Rod seal	
72185133	Inlet poppet	Inlet Check Valve Assembly
72185141	Inlet poppet spring	
72185149	Sleeve	
72185167	Discharge poppet guide	Discharge Check Valve Assembly
72185185	Discharge poppet	
72185192	Discharge poppet seat	
72185200	Discharge poppet spring	
20434082	O-ring	End Cap
05122007	O-ring	High Pressure Cylinder
20434082	O-ring	Subplate Adapter
10074383	O-ring	
72185208	Rod seal	
72185226	Retaining ring	
72185234	Poppet/Seat Assembly	Pressure Control Valve Assembly
10149029	320 grit paper	
10087385	FML-2 food grade grease	
49832199	JL-M anti-seize	

Figure 5-5: Minor Maintenance Kit

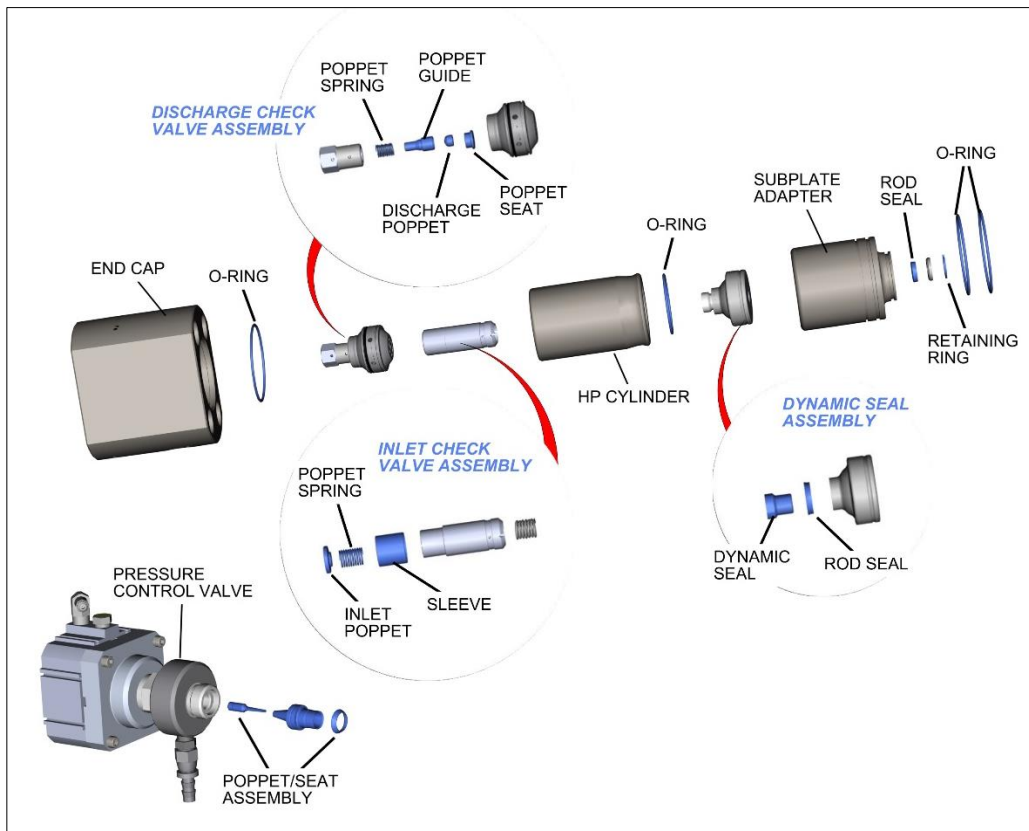

- Read the entire procedure before beginning service, paying particular attention to safety instructions.
- All parts of the kit should be installed at the same time. Do not replace components individually.
- All components should be clean and free of debris prior to assembly. Keeping the work area clean is important while working on the equipment.



Failure to follow these instructions could result in premature failure or equipment damage.

1. Turn the machine off and observe the appropriate Lockout/Tagout procedures.



Severe injury can result if the machine is not properly locked out. Observe electrical Lockout/Tagout procedures before performing maintenance.

Ensure all pressure is relieved or blocked from the high pressure circuits before performing maintenance.



2. Disconnect all high and low pressure connections, following the procedure, High and Low Pressure Connections.
3. Unload the tie rods, following the procedure, Unloading the Tie Rods.
4. Remove the end cap assembly, high pressure cylinder and inlet check valve assembly. Remove and discard the inlet poppet, inlet poppet compression spring and sleeve from the inlet check valve assembly.

Figure 5-6: Minor Kit Disassembly

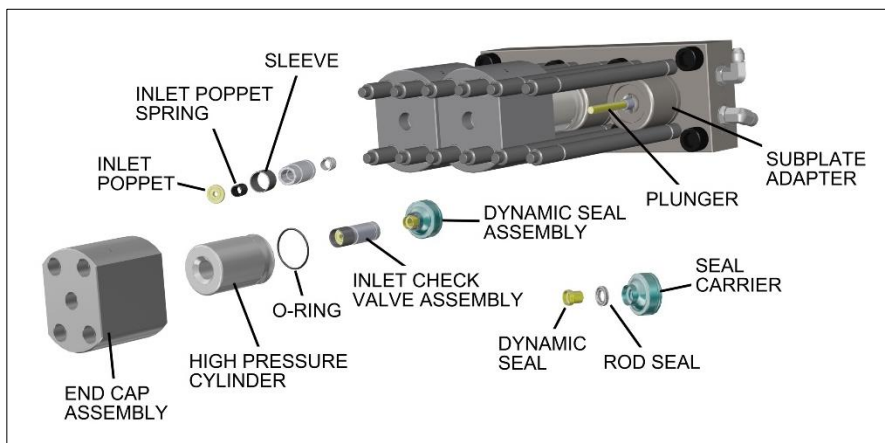

5. Remove and discard the o-ring from the inside diameter of the high pressure cylinder.
6. If the dynamic seal carrier was not removed from the high pressure cylinder, position two flat screwdrivers in the groove in the outside diameter of the carrier. Carefully pry the carrier from the cylinder.
7. Remove and discard the dynamic seal and rod seal. If necessary, use pliers to remove the rod seal from the seal carrier.



Use care when removing the dynamic seal and rod seal. Do not scratch or nick the seal carrier bore.

8. Remove the subplate adapter. If necessary, use pry bars or screwdrivers to remove the adapter.
9. Remove the retaining ring from the adapter using snap ring pliers.
10. Remove the seal spacer and rod seal.
11. Remove the two o-rings from the outer diameter of the adapter.
12. Discard the rod seal, o-rings and retaining ring. The seal spacer will be reused.



13. Place the end cap on a workbench vertically with the discharge check valve end up.

Figure 5-7: Discharge Check Valve Assembly Removal

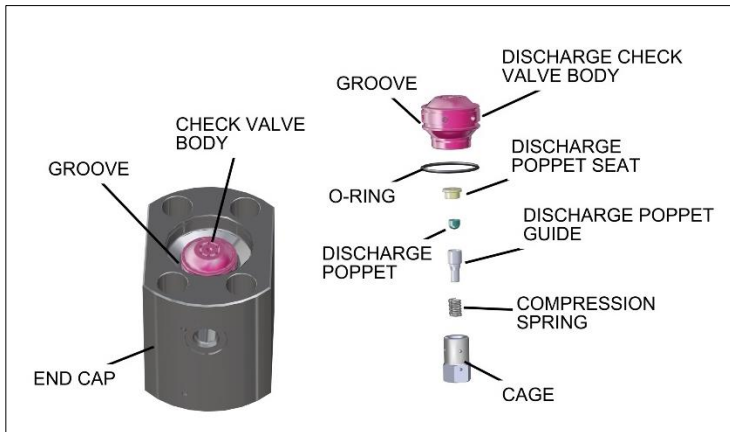

14. Position two flat screwdrivers in the circumferential groove in the outside diameter of the check valve body and remove the check valve assembly from the end cap. Use care not to damage the body or the end cap.
15. Remove and retain the o-ring from the check valve body.
16. Place the check valve body in the provided rebuild clamp.



To prevent metal from being introduced into the openings on the outer circumference of the check valve body, **do not** cover the holes with the rebuild clamp.

17. Loosen and remove the cage.
18. Remove the compression spring, discharge poppet guide, discharge poppet and discharge poppet seat. Discard the poppet, poppet seat, poppet guide and compression spring. These components will not be reused.
19. Repeat these steps for the remaining discharge check valves.

Lapping the Discharge Check Valve Body



The check valve body is lapped with the discharge poppet and seat removed to prevent contamination when lapping.

1. Use the glass lapping plate from the tool kit and 320 grit lapping paper from the repair kit.
2. Lightly wet the paper with water. Place the inlet face of the check valve body against the lapping paper. Use even, deliberate strokes, rotating the valve body approximately 10-15 degrees after each stroke.



Be very careful not to rock the valve body while lapping the surface. Flatness is very critical.

3. Lap the valve body until it is flat and smooth. Be careful not to cause additional damage by tilting or tipping the part while lapping.
4. Thoroughly clean the openings in the check valve body to remove particles from the lapping process.

Discharge Check Valve Assembly Installation

1. Insert the new discharge poppet into the new poppet guide.

NOTE

Install the poppet into the guide with the back radius of the poppet going in first. The counterbore in the discharge poppet is visible after installation.

2. Position the new poppet spring around the poppet guide. The spring will be loose on the guide.
3. Place the assembly into the cage along with the new poppet seat.
4. With the threaded end of the cage facing up, hold the cage so the installed components will not fall out.
5. Apply a thin film of Pure Goop to the threads on the cage and carefully thread the check valve body onto the cage.
6. Secure the check valve body in the rebuild clamp with the inlet face downward.
7. Secure the rebuild clamp in a vise. Torque the discharge cage to 30 ft-lb (41 Nm).
8. Repeat Steps 1-8 for the remaining discharge check valves.

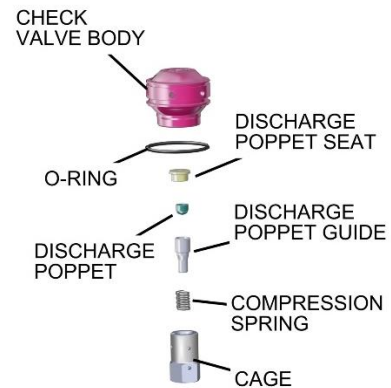

End Cap Assembly

1. Lightly lubricate the existing check valve o-ring with FML-2 grease and install it into the groove on the check valve body.
2. Remove and discard the existing o-ring in the inner diameter of the end cap. Lightly lubricate the new o-ring with FML-2 grease and install it in the groove of the end cap.
3. With the cage facing the end cap, insert the check valve body into the end cap.
4. Repeat these steps for the remaining end caps.

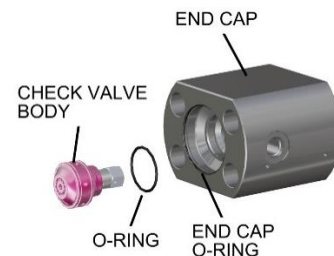

Plunger Torque Verification

1. Carefully slide the plunger nut tool over the plunger and plunger nut. Torque the plunger nut to 20 ft-lbs (27 Nm).
2. Rotate the pulley to fully extend the next plunger to be checked.
3. Repeat these steps for the remaining plungers.
4. When finished, clean any dirt or grease from all of the plungers.

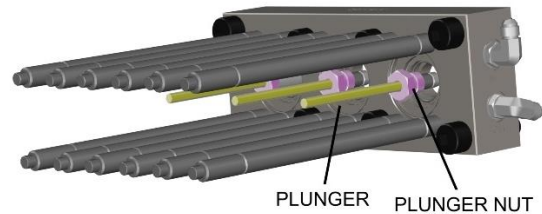

Subplate Adapter Installation

1. Ensure the tie rods are firmly seated in the subplate.
2. Clean the cooling water holes in the adapter.
3. With the v-shaped face toward the subplate adapter, install the new rod seal in the counterbore of the adapter.
4. Place the existing seal spacer in the counterbore with the chamfered side down, toward the rod seal.
5. Secure the rod seal and spacer with the new retaining ring.
6. Lubricate the two new o-rings with FML-2 grease and install them on the adapter.
7. Slide the adapter over the plunger until it engages the counterbore of the subplate.
8. Repeat this procedure for the remaining subplate adapters.

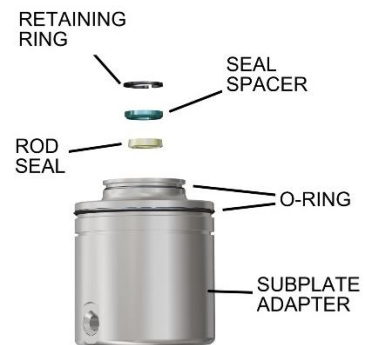

Dynamic Seal Installation

1. Inspect the dynamic seal carrier for damage and cleanliness. Clean or replace as required.
2. Ensure the guide bearing in the seal carrier is flush with the face of the carrier and is in good condition. If cracks or loose pieces are detected, replace the seal carrier.

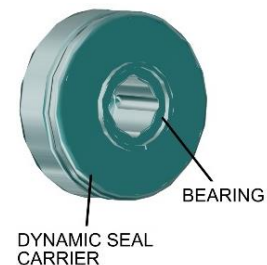

3. Install the new rod seal with the v-shaped groove facing away from the carrier.
4. Install the new dynamic seal into the inner diameter of the rod seal, making sure the dynamic seal is fully seated against the carrier.

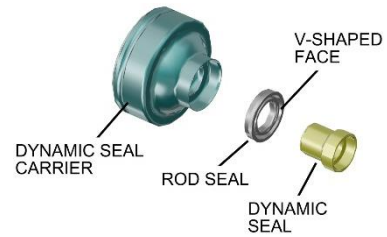

Ensure the plungers are clean and free of any scratches or damage before installing the dynamic seal carrier. The subplate adapter/seal carrier interface must be clean and free of debris.

5. Slide the dynamic seal carrier onto the plunger until the carrier is seated against the register of the subplate adapter.
6. Repeat this procedure for the remaining dynamic seal assemblies.

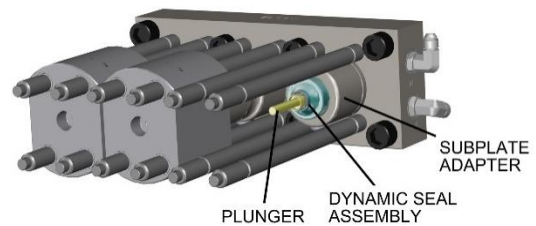

High Pressure Cylinder Installation

1. Lubricate the new o-ring with FML-2 grease and position it in the groove in the high pressure cylinder.
2. Slide the high pressure cylinder over the plunger and seat it against the dynamic seal carrier. Position the cylinder with the weep hole facing down.
3. Repeat this procedure for the remaining high pressure cylinders.

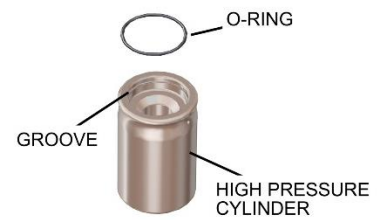
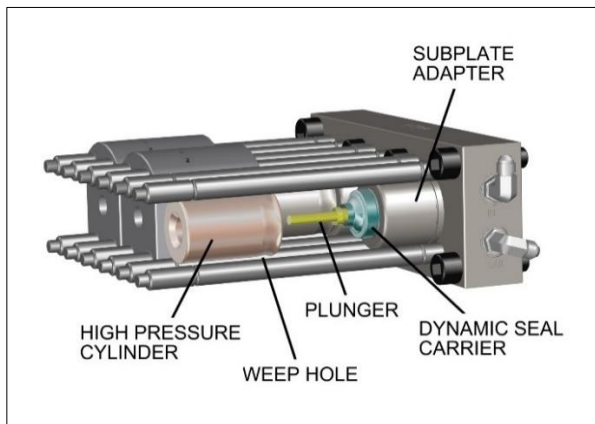

Figure 5-8: High Pressure Cylinder Installation



NOTE

A small amount of force may be required to seat the cylinder against the seal carrier.

Inlet Check Valve Assembly Installation

1. Position the new inlet poppet spring over the shouldered side of the new inlet poppet.
2. Apply pressure to the spring until it snaps into place. Rotate the poppet to ensure the spring is firmly attached.
3. Repeat this process for the remaining inlet poppets.
4. Position the dynamic seal compression spring into the tapered end of the filler tube.
5. Insert the inlet poppet assembly into the opposite end of the filler tube, spring end first.
6. Partially install the new sleeve so it surrounds the inlet poppet and spring.

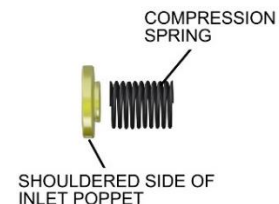
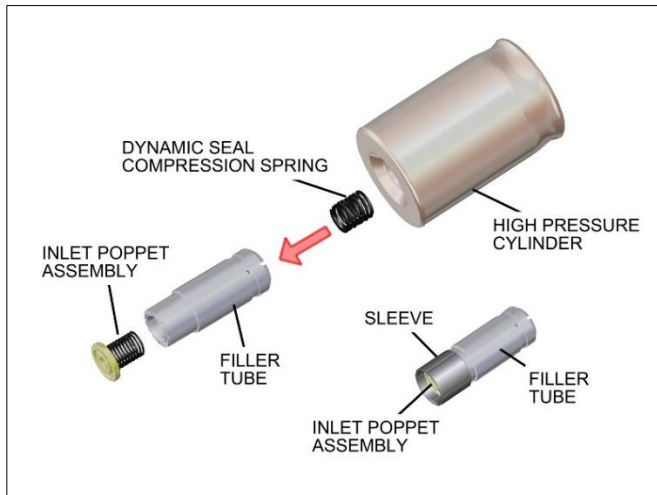

Figure 5-9: Inlet Check Valve Assembly Installation



NOTE

The sleeve helps align the poppet with the discharge check valve body and prevents pinching of the inlet poppet between the discharge check valve and the filler tube during installation.

7. Insert the inlet check valve assembly, spring end first, into the high pressure cylinder, making sure to engage the spring into the dynamic seal.
8. Repeat this procedure for the remaining inlet check valve assemblies.

End Cap Installation



The end cap must be installed in one fluid motion toward the crankcase. **Do not** allow the end cap to spring back from the high pressure cylinder while installing. This movement can pinch the inlet poppet, causing damage.



The split bearings must be completely seated in the end cap. Incorrect installation will cause inappropriate loading of the high pressure position.

1. Ensure all eight of the split bearings are in position in the end cap.
2. Align the end cap so it will slide over the tie rods, then carefully slide the end cap toward the crankcase until the discharge check valve makes contact with the inlet poppet.
3. Continue to slide the end cap back until the high pressure cylinder engages the o-ring on the end cap and the discharge check valve seats against the cylinder.
4. Temporarily hand-tighten one of the hex nuts to prevent the end cap from springing back.
5. Repeat this procedure for the remaining end caps.
6. Install the remaining washers and hex nuts and hand-tighten.
7. Follow the procedure Loading the Tie Rods to load the tie rods.

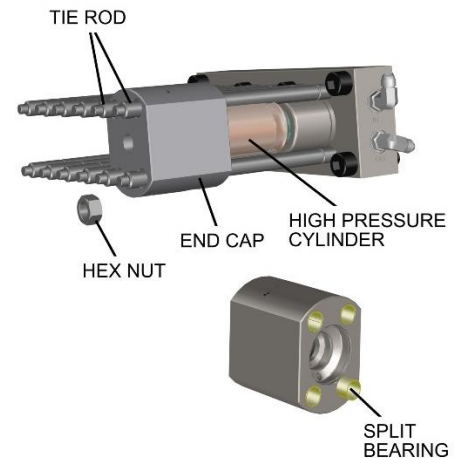

Pressure Control Valve Maintenance

1. Place the high pressure manifold in a soft-jaw vise.
2. Use a 1-1/4 inch wrench to remove the pressure control valve from the manifold.
3. Remove the valve adapter from the valve body.

Figure 5-10: Pressure Control Valve Maintenance

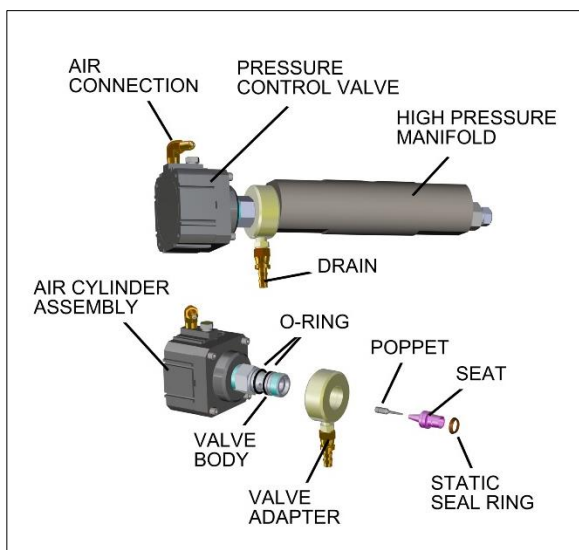

4. Remove and discard the poppet, seat and static seal ring from the valve body.

NOTE

Needle nose pliers may be required to remove the poppet from the assembly.

5. Lubricate the o-rings on the valve body with FML-2 grease and slide the adapter onto the valve body.
6. Install the new static seal ring on the new seat and loosely install the new poppet into the seat. This will ensure the components stay together when installing the valve onto the manifold.



Do not press the poppet into the seat.

7. Position the poppet and seat assembly into the end of the valve body.
8. Lubricate the threads on the valve body with Pure Goop and thread the pressure control valve assembly into the high pressure manifold. Torque the valve body to 190 ft-lbs (258 Nm).
9. Remove the manifold assembly from the vise.
10. Follow the procedure High and Low Pressure Connections to reconnect all piping and connections.
11. Remove the plug, from the crankcase drain and completely drain the oil.
12. Reinstall the plug, and fill the crankcase with oil to the level indicated on the dipstick.
13. Follow the startup procedure in Section 4, Operation, before returning the pump to service.

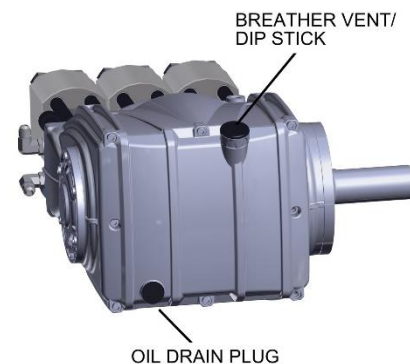

NOTE

The crankcase oil is replaced every 500 hours as part of the mandatory maintenance schedule. Replace the oil sooner if a fluid sample is brown or blackish in color.



5.6 Major Maintenance Kit

The major maintenance kit must be installed every 1,500 hours. Use the following procedure to install the major maintenance kit. The major maintenance kit contains the following replacement components.

Table 5-4
Major Maintenance Kit
72185284

Part Number	Component	Subassembly
72185117	Dynamic seal	Dynamic Seal Assembly
72185125	Rod seal	
72185291	Seal carrier assembly	
72185133	Inlet poppet	Inlet Check Valve Assembly
72185141	Inlet poppet spring	
72185149	Sleeve	
72186948	Dynamic seal compression spring	
72185167	Discharge poppet guide	Discharge Check Valve Assembly
72185185	Discharge poppet	
72185192	Discharge poppet seat	
72185200	Discharge poppet spring	
72185307	Valve body	
10074383	O-ring	End Cap
20434082	O-ring	
72185325	HP Cylinder	High Pressure Cylinder
05122007	O-ring	
20434082	O-ring	Subplate Adapter
10074383	O-ring	
72185208	Rod seal	
72185226	Retaining ring	
72186940	Compression spring	Plunger Assembly
72186914	Plunger	
72186890	V-belts	Belt Drive
72185234	Poppet/Seat Assembly	Pressure Control Valve Assembly
10087385	FML-2 food grade grease	
49832199	JL-M anti-seize	

Figure 5-11: Major Maintenance Kit

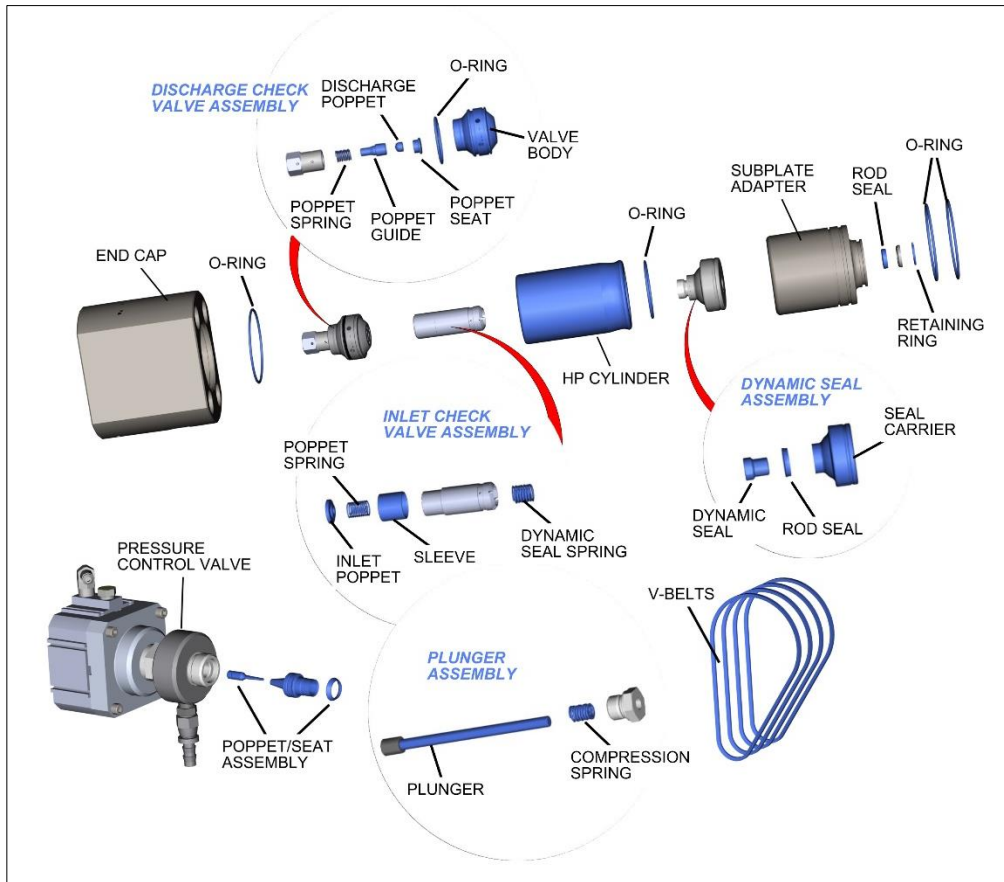

- Read the entire procedure before beginning service, paying particular attention to safety instructions.
- All parts of the kit should be installed at the same time. Do not replace components individually.
- All components should be clean and free of debris prior to assembly. Keeping the work area clean is important while working on the equipment.



Failure to follow these instructions could result in premature failure or equipment damage.

1. Turn the machine off and observe the appropriate Lockout/Tagout procedures.



Severe injury can result if the machine is not properly locked out. Observe electrical Lockout/Tagout procedures before performing maintenance.

Ensure all pressure is relieved or blocked from the high pressure circuits before performing maintenance.



2. Disconnect all high and low pressure connections, following the procedure, High and Low Pressure Connections.
3. Unload the tie rods, following the procedure, Unloading the Tie Rods.
4. Remove the end cap assembly, high pressure cylinder and inlet check valve assembly. Discard the inlet poppet, inlet poppet compression spring, sleeve and dynamic seal compression spring from the inlet check valve assembly. Discard the high pressure cylinder and the o-ring.

Figure 5-12: Major Kit Disassembly

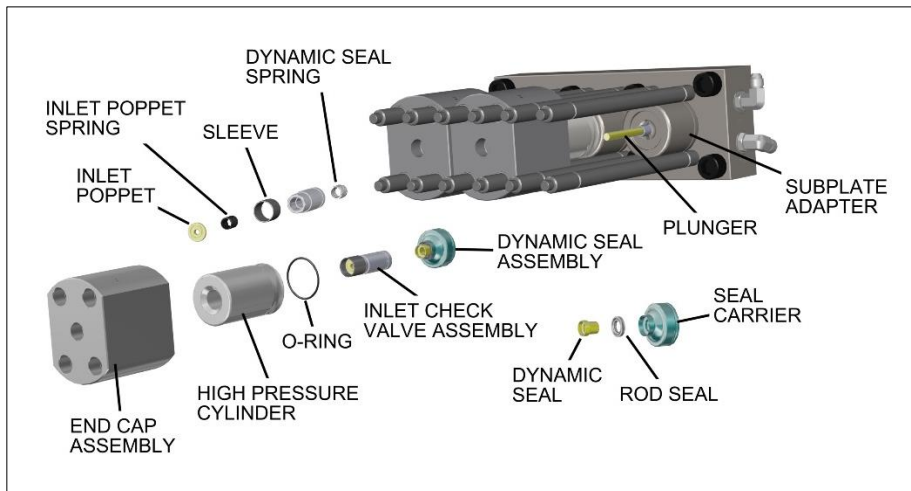

5. If the dynamic seal carrier was not removed from the high pressure cylinder, position two flat screwdrivers in the groove in the outside diameter of the carrier. Carefully pry the carrier from the cylinder.
6. Remove and discard the complete assembly to include the dynamic seal, rod seal and carrier.



Use care when removing the dynamic seal and rod seal. Do not scratch or nick the seal carrier bore.

7. Remove the subplate adapter. If necessary, use pry bars or screwdrivers to remove the adapter.
8. Remove the retaining ring from the adapter using snap ring pliers.
9. Remove the seal spacer and rod seal.
10. Remove the two o-rings from the outer diameter of the adapter.
11. Discard the rod seal, o-rings and retaining ring. The seal spacer will be reused.



12. Place the end cap on a workbench vertically with the discharge check valve end up.

Figure 5-13: Discharge Check Valve Assembly Removal

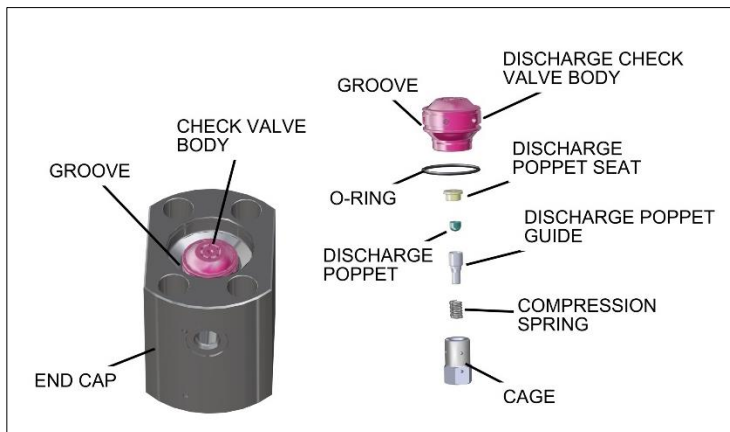

13. Position two flat screwdrivers in the circumferential groove in the outside diameter of the check valve body and remove the check valve assembly from the end cap. Use care not to damage the body or the end cap.
14. Remove and discard the o-ring from the check valve body.
15. Place the check valve body in the provided rebuild clamp.



To prevent metal from being introduced into the openings on the outer circumference of the check valve body, **do not** cover the holes with the rebuild clamp.

16. Loosen and remove the cage.
17. Remove the compression spring, discharge poppet guide, discharge poppet and discharge poppet seat. Discard the poppet, poppet seat, poppet guide, compression spring and valve body. Do not reuse these components. Retain the cage.
18. Repeat these steps for the remaining discharge check valves.

Discharge Check Valve Assembly Installation

1. Insert the new discharge poppet into the new poppet guide.



Install the poppet into the guide with the back radius of the poppet going in first. The counterbore in the discharge poppet is visible after installation.

2. Position the new poppet spring around the poppet guide. The spring will be loose on the guide.
3. Place the assembly into the existing cage along with the new poppet seat.
4. With the threaded end of the cage facing up, hold the cage so the installed components will not fall out.
5. Apply a thin film of Pure Goop to the threads on the cage and carefully thread the new check valve body onto the cage.
6. Secure the check valve body in the rebuild clamp with the inlet face downward.

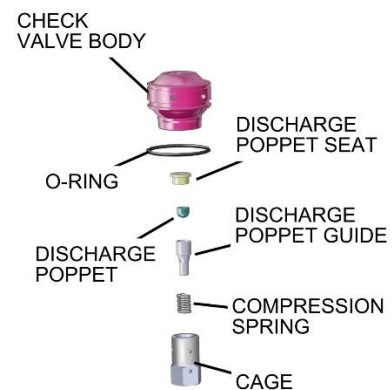

7. Secure the rebuild clamp in a vise. Torque the discharge cage to 30 ft-lb (41 Nm).
8. Repeat Steps 1-8 for the remaining discharge check valves.

End Cap Assembly

1. Lightly lubricate the new check valve o-ring with FML-2 grease and install it into the groove on the new check valve body.
2. Remove and discard the existing o-ring in the inner diameter of the end cap. Lightly lubricate the new o-ring with FML-2 grease and install it in the groove of the end cap.
3. With the cage facing the end cap, insert the check valve body into the end cap.
4. Repeat these steps for the remaining end caps.

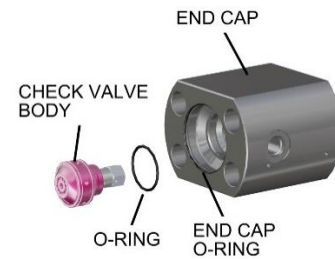

Plunger Removal and Installation

1. Remove the belt cover and rotate the pulley by hand to fully extend any of the three plungers.
2. Carefully slide the plunger nut tool over the plunger and remove the plunger nut, compression spring and plunger. Discard the plunger and compression spring. Retain the plunger nut for reuse.

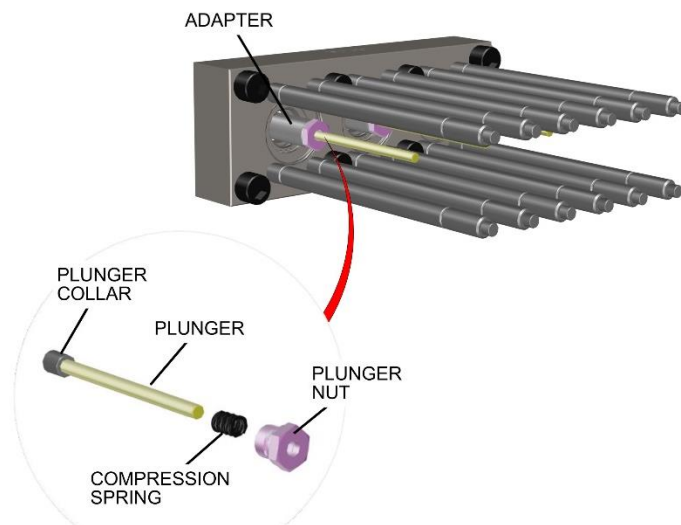

3. Repeat these steps for the remaining plungers.
4. To install the new components rotate the pulley by hand to fully extend any of the three positions.
5. Place the new compression spring in the counter bore of the plunger nut and carefully slide the plunger nut over the plunger until the spring contacts the plunger collar.
6. Thread the plunger nut into the adapter.
7. Carefully slide the plunger nut tool over the plunger and torque the plunger nut to 20 ft-lbs (27 Nm).

8. Repeat these steps for the remaining positions.
9. When finished, clean any dirt or grease from all of the plungers.

Subplate Adapter Installation

1. Ensure the tie rods are firmly seated in the subplate.
2. Clean the cooling water holes in the adapter.
3. With the v-shaped face toward the subplate adapter, install the new rod seal in the counterbore of the adapter.
4. Place the existing seal spacer in the counterbore with the chamfered side down, toward the rod seal.
5. Secure the rod seal and spacer with the new retaining ring.



6. Lubricate the two new o-rings with FML-2 grease and install them on the adapter.
7. Slide the adapter over the plunger until it engages the counterbore of the subplate.
8. Repeat this procedure for the remaining subplate adapters.

Dynamic Seal Installation

1. Inspect the new dynamic seal carrier for cleanliness. Clean as required.
2. Ensure the guide bearing in the seal carrier is flush with the face of the carrier and is in good condition. If cracks or loose pieces are detected, replace the seal carrier.
3. Install the new rod seal with the v-shaped groove facing away from the carrier.
4. Install the new dynamic seal into the inner diameter of the rod seal, making sure the dynamic seal is fully seated against the carrier.

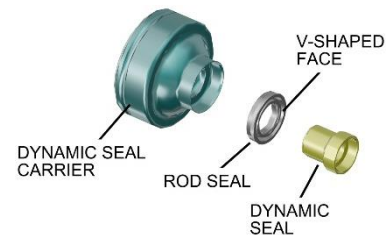
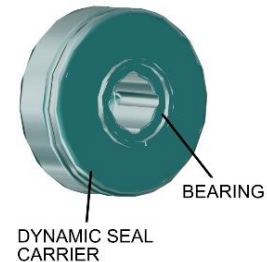



Ensure the plungers are clean and free of any scratches or damage before installing the dynamic seal carrier. The subplate adapter/seal carrier interface must be clean and free of debris.

- Slide the dynamic seal carrier onto the plunger until the carrier is seated against the register of the subplate adapter.
- Repeat this procedure for the remaining dynamic seal assemblies.

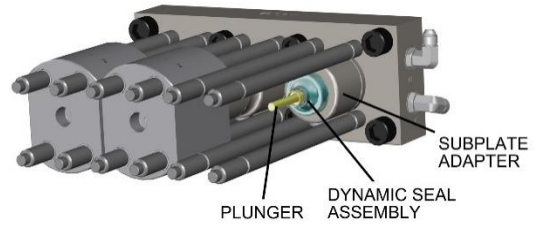

High Pressure Cylinder Installation

- Lubricate the new o-ring with FML-2 grease and position it in the groove in the high pressure cylinder.
- Slide the high pressure cylinder over the plunger and seat it against the dynamic seal carrier. Position the cylinder with the weep hole facing down.
- Repeat this procedure for the remaining high pressure cylinders.



Figure 5-14: High Pressure Cylinder Installation

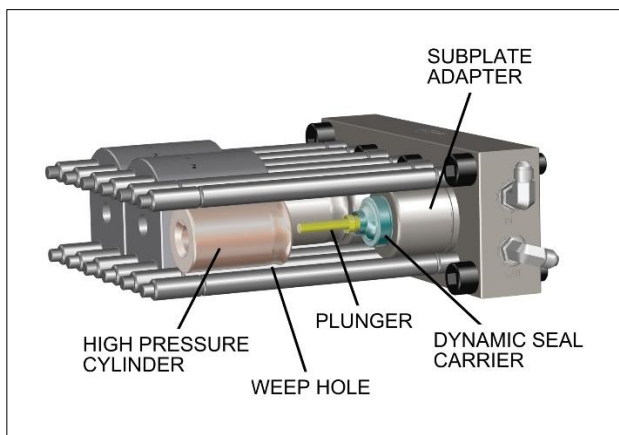

NOTE

A small amount of force may be required to seat the cylinder against the seal carrier.

Inlet Check Valve Assembly Installation

1. Position the new inlet poppet spring over the shouldered side of the new inlet poppet.
2. Apply pressure to the spring until it snaps into place. Rotate the poppet to ensure the spring is firmly attached.
3. Repeat this process for the remaining inlet poppets.

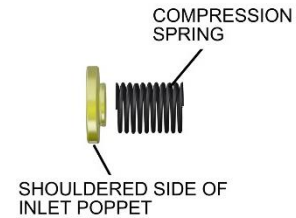

4. Position the new dynamic seal compression spring into the tapered end of the filler tube.
5. Insert the inlet poppet assembly into the opposite end of the filler tube, spring end first.
6. Partially install the new sleeve so it surrounds the inlet poppet and spring.

Figure 5-15: Inlet Check Valve Assembly Installation

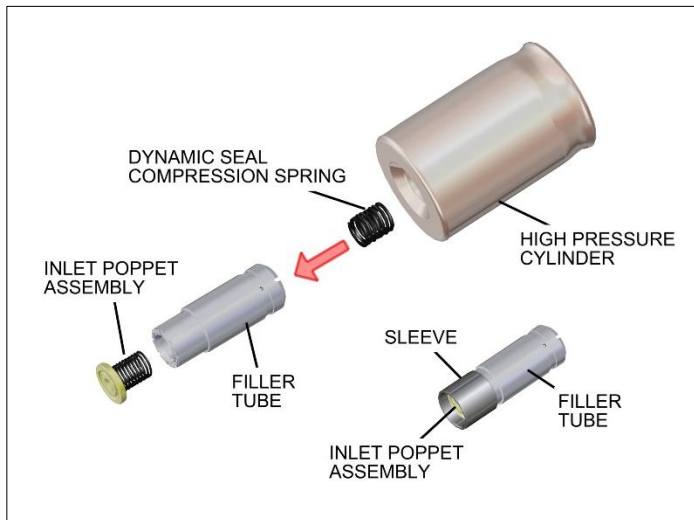

NOTE

The sleeve helps align the poppet with the discharge check valve body and prevents pinching of the inlet poppet between the discharge check valve and the filler tube during installation.

7. Insert the inlet check valve assembly, spring end first, into the high pressure cylinder, making sure to engage the spring into the dynamic seal.
8. Repeat this procedure for the remaining inlet check valve assemblies.

End Cap Installation



The end cap must be installed in one fluid motion toward the crankcase. **Do not** allow the end cap to spring back from the high pressure cylinder while installing. This movement can pinch the inlet poppet, causing damage.



The split bearings must be completely seated in the end cap. Incorrect installation will cause inappropriate loading of the high pressure position.

1. Ensure all eight of the split bearings are in position in the end cap.
2. Align the end cap so it will slide over the tie rods, then carefully slide the end cap toward the crankcase until the discharge check valve makes contact with the inlet poppet.
3. Continue to slide the end cap back until the high pressure cylinder engages the o-ring on the end cap and the discharge check valve seats against the cylinder.
4. Temporarily hand-tighten one of the hex nuts to prevent the end cap from springing back.
5. Repeat this procedure for the remaining end caps.
6. Install the remaining washers and hex nuts and hand-tighten.
7. Follow the procedure Loading the Tie Rods to load the tie rods.

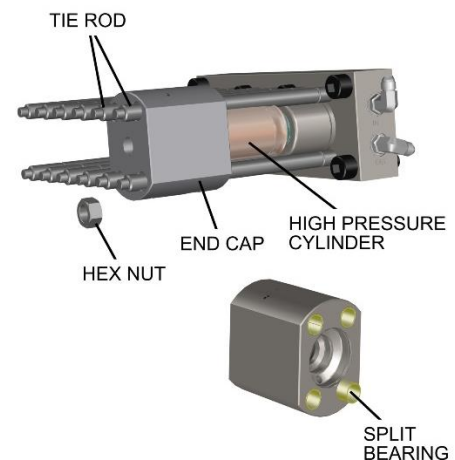

Pressure Control Valve Maintenance

1. Place the high pressure manifold in a soft-jaw vise.
2. Use a 1-1/4 inch wrench to remove the pressure control valve from the manifold.
3. Remove the valve adapter from the valve body.

Figure 5-16: Pressure Control Valve Maintenance

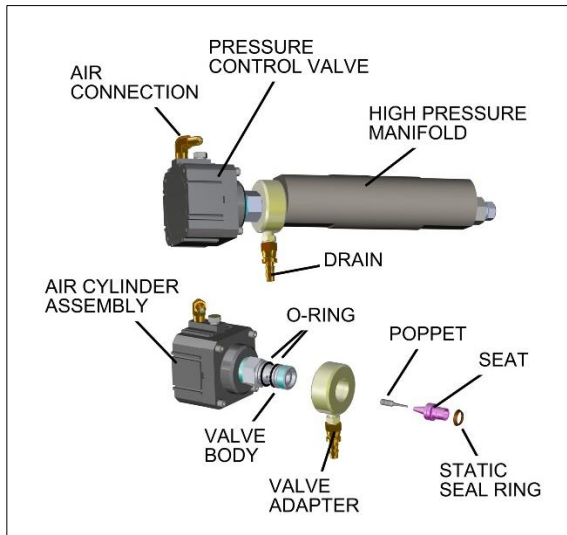

4. Remove and discard the poppet, seat and static seal ring from the valve body.
5. Remove the valve adapter from the valve body.

NOTE

Needle nose pliers may be required to remove the poppet from the assembly.

6. Lubricate the valve o-rings with FML-2 grease and slide the adapter onto the valve body.
7. Install the new static seal ring on the new seat and loosely install the new poppet into the seat. This will ensure the components stay together when installing the valve onto the manifold.



Do not press the poppet into the seat.

8. Position the poppet and seat assembly into the end of the valve body.
9. Lubricate the threads on the valve body with Pure Goop and thread the pressure control valve assembly into the high pressure manifold. Torque the valve body to 190 ft-lbs (258 Nm).
10. Remove the manifold assembly from the vise.
11. Follow the procedure High and Low Pressure Connections to reconnect all piping and connections.

12. Remove the plug, from the crankcase drain and completely drain the oil.
13. Reinstall the plug, and fill the crankcase with oil to the level indicated on the dipstick.

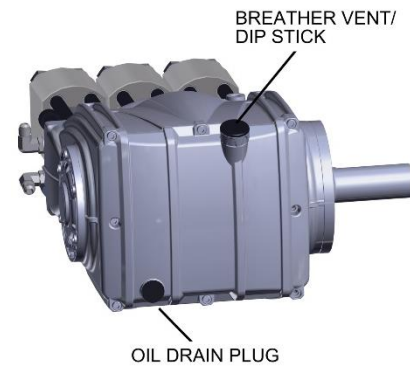

NOTE

The crankcase oil is replaced every 500 hours as part of the mandatory maintenance schedule. Replace the oil sooner if a fluid sample is brown or blackish in color.

Replacing the Belts

1. Remove the belt guard.
2. Loosen the four, flanged nuts mounting the transmission housing to the electric motor.

Figure 5-17: Replacing the Belts

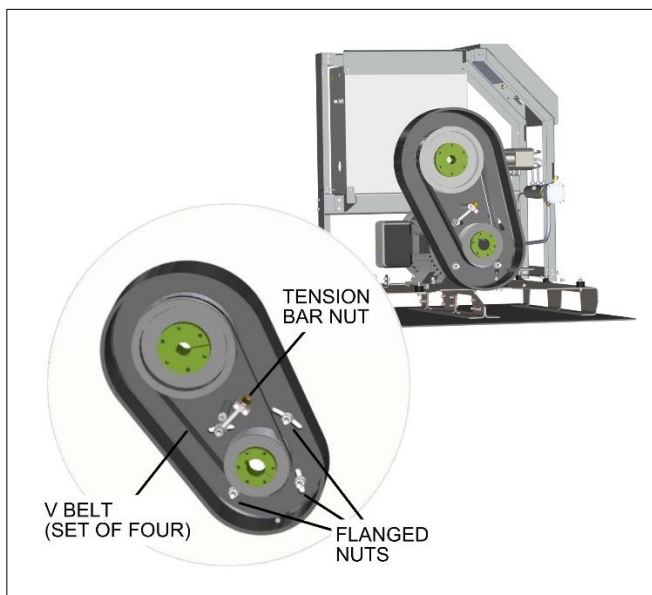

3. Turn the nut on the tension bar counter-clockwise to allow the weldment to rotate so the belts can be removed.
4. Install the four new belts.

NOTE

Replace all four belts at the same time to maintain consistent performance of the drive system.

5. Turn the nut on the tension bar clockwise until there is tension on the belts.
6. Adjust the belt tension following the procedure, Tensioning and Aligning the Belt Drive.
7. Follow the startup procedure in Section 4, Operation, before returning the pump to service.

5.7 Pressure Control Valve Maintenance Kit

Use the following procedure to install the pressure control valve maintenance kit. The PCV maintenance kit is installed every other time a major maintenance kit is installed. The PCV maintenance kit contains the following replacement components.

Table 5-5
Pressure Control Valve Maintenance Kit
72185333

Part Number	Component	Main Assembly
72185341	Bearing assembly	Pressure Control Valve Assembly
72185349	Plunger	
72185357	Plunger seal	
10113884	O-ring	
72129276	O-ring	
72129268	O-ring	
72185234	Poppet/Seat assembly*	
10087385	FML-2 food grade grease	

***Note:** Included in the major maintenance kit

Figure 5-18: Pressure Control Valve Maintenance Kit

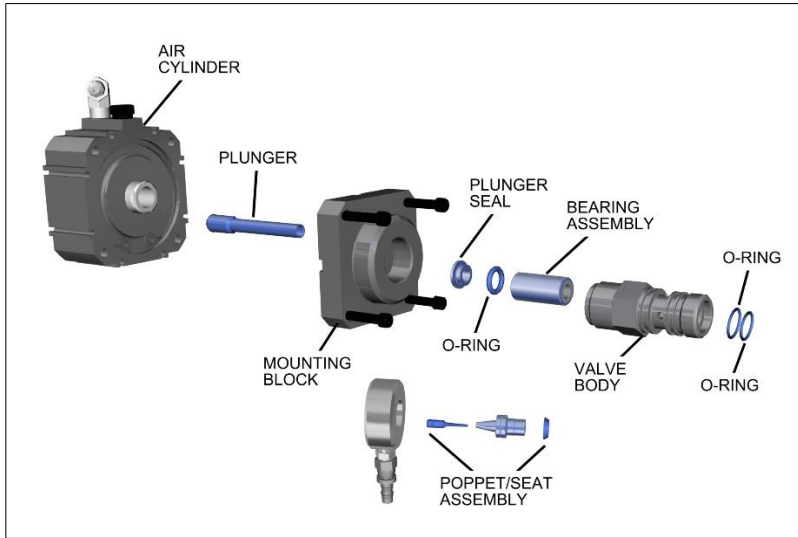

- Read the entire procedure before beginning service, paying particular attention to safety instructions.
- All parts of the kit should be installed at the same time. Do not replace components individually.
- All components should be clean and free of debris prior to assembly. Keeping the work area clean is important while working on the equipment.



Failure to follow these instructions could result in premature failure or equipment damage.

1. Turn the machine off and observe the appropriate Lockout/Tagout procedures.



Severe injury can result if the machine is not properly locked out. Observe electrical Lockout/Tagout procedures before performing maintenance.

Ensure all pressure is relieved or blocked from the high pressure circuits before performing maintenance.



2. Reduce the air pressure to 0 psi (0 bar), and remove the air and drain lines from the pressure control valve.
3. Remove the high pressure manifold from the pump and place in a soft jawed vise.
4. Use a 1-1/4 inch wrench to remove the valve from the manifold.

Figure 5-19: Pressure Control Valve Removal

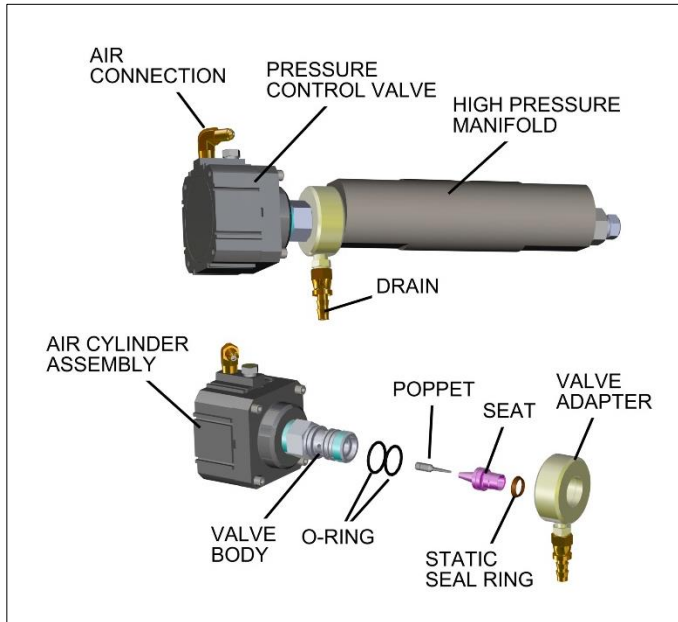

5. Remove and discard the poppet, seat and static seal ring from the valve body.

NOTE

Needle nose pliers by be required to remove the poppet from the assembly.

6. Remove the valve adapter and o-rings from the valve body. Discard the o-rings.
7. Place the air cylinder assembly in a soft jaw vise. Use a 1-1/4 inch combination wrench to remove the valve body from the air cylinder.
8. Use an Allen wrench to remove the four cap screws from the air cylinder. Separate the mounting block to access the plunger.

Figure 5-20: Pressure Control Valve Maintenance Kit

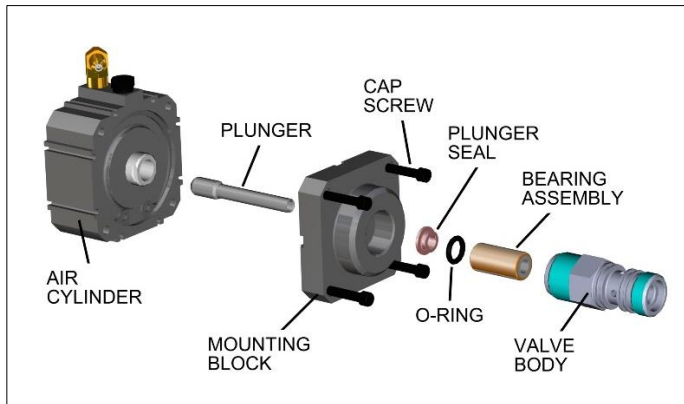

9. Remove and discard the plunger.
10. Using the bearing removal/installation tool (P/N 72185492), push the bearing assembly from the bore of the valve body. Discard the bearing assembly.
11. Remove and discard the plunger seal and o-ring.
12. Slide the new plunger through the bore of the mounting block.
13. Reinstall the mounting block onto the air cylinder and tighten the four cap screws.
14. Inspect the other wear components for any signs of deterioration and repair or replace as necessary.
15. Using the bearing removal/installation tool, push the new bearing assembly into the bore of the valve body.
16. Lubricate the new plunger seal with FML-2 food grade grease and install the new o-ring onto the plunger seal. With the o-ring side toward the valve body, install the components in the body.
17. With the air cylinder in the soft jaw vise, slide the valve body over the plunger and thread the body into the mounting block until the body is firmly seated. No extreme torque is required.
18. Clean any remaining debris from the high pressure port in the manifold.
19. Lubricate the two new o-rings with FML-2 food grade grease and slide the o-rings onto the valve body.
20. Install the valve adapter on the valve body.
21. Install the new static seal ring on the new seat and loosely install the new poppet into the seat. This will ensure the components stay together when installing the valve onto the manifold.



Do not press the poppet into the seat.

22. Position the poppet and seat assembly into the end of the valve body.
23. Lubricate the threads on the valve body with Pure Goop and thread the pressure control valve assembly into the high pressure manifold. Torque the valve body to 190 ft-lbs (258 Nm).
24. Install the air and drain lines.
25. Follow the startup procedure in Section 4, Operation, before returning the pump to service.

5.8 Low Pressure Filter Maintenance

To ensure water quality and supply to the high pressure assembly, the filter elements will require routine servicing and maintenance. The procedures for servicing these components are detailed below.

The life of the filter element is directly related to the quality of the inlet water. The condition of the filter element can be monitored by observing the post-filter pressure gauge on the control display. The elements should be replaced when the pressure drops below 18 psi (1.2 bar) when the pump is running.

NOTE

Check the pressure gauge only when the pump is running at full speed and operating at full output pressure. When the pump stops, the pressure will increase substantially, even with a dirty filter.

1. Shut the system down.
2. Turn the supply water off.
3. Using a strap wrench, remove the filter housings.
4. Remove the filter elements from the housings and discard.
5. Inspect the contents of the housings. This inspection can provide early warning of a change in supply water quality.

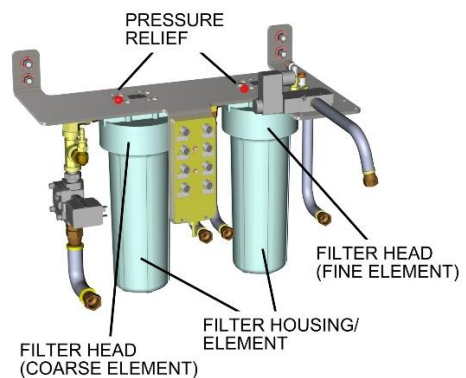

The fine and coarse elements must be installed in the correct position as labeled on the pump. Failure to do so could shorten pump life.

6. Clean the housings and install new filter elements.
7. Use the strap wrench to install the housings on the filter heads.
8. Turn the supply water on and check for leaks.



The supply water must be on before starting the pump. Failure to do so could severely damage the pump.

9. Turn the pump on.
10. When the filter housings are pressurized, press the red, pressure-relief buttons on top of the housings to remove trapped air.

5.9 Servicing the Crankcase

The only service required for the crankcase is to maintain adequate levels of clean oil and to replace worn piston rod seal assemblies.

Rebuilding the crankcase is not recommended.

Lubricating the Pump

Use of Shell Morlina 100 hydraulic oil (ISO 100) is recommended. Other manufacturer's equivalent products can be used.

When operating the pump in an environment with an ambient temperature greater than 86° F (30° C), a heavier oil is recommended. Contact KMT Technical Service for additional information.

Maintain oil level between the high and low level marks on the dipstick inserted through the crankcase cover.

- Check oil levels regularly
- Change the oil every 500 hours
- Change the oil sooner if it is brown or blackish in color
- Change the oil immediately if water droplets are seen on the dipstick

Tensioning and Aligning the Belt Drive

The pulleys and belts should be serviced during each major maintenance service interval or if the belts fail.

Proper belt tension is essential for optimum operation. Follow these general rules when tensioning the drive:

- The ideal tension for the belt drive is the lowest tension at which the belt will not slip under the highest load condition.

- Check tension on a new drive belt frequently during the first day of operation and periodically thereafter.
 - Excessive tension shortens belt and bearing life.
 - Keep the belt and pulleys free from oil, grease, cutting lubricants or belt dressing. Any of these can cause the belt to slip.
 - If a V-belt slips, it is not at proper tension and needs to be tightened.
 - Do not use substitute hardware.
1. Turn the machine off and observe the appropriate Lockout/Tagout procedures.



Severe injury can result if the machine is not properly locked out. Observe electrical Lockout/Tagout procedures before performing maintenance.

Ensure all pressure is relieved or blocked from the high pressure circuits before performing maintenance.



2. To verify the tension, place the belt tension gauge in the center of the belt midway between pulleys. Align the sides of the gauge parallel to the edges of the belt.

Figure 5-21: Tensioning the Belt Drive

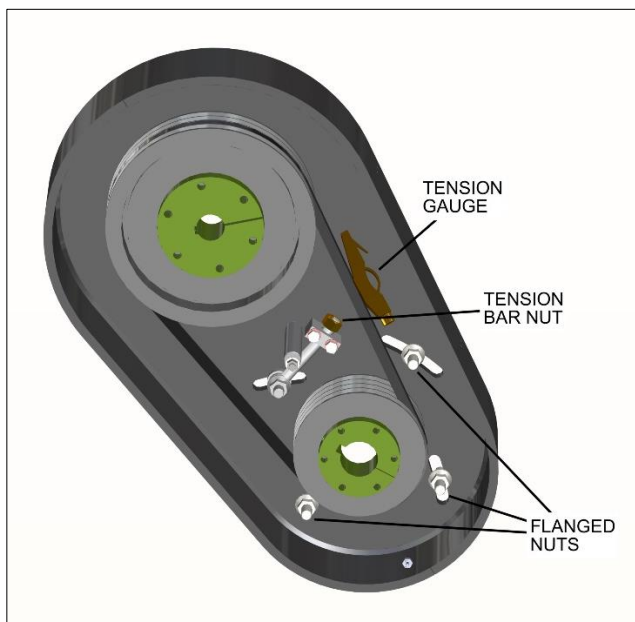

3. Verify the indicator arm is positioned completely down and place your index finger in the finger strap on top of the click pad.
4. Press down slowly until it pad clicks. Immediately stop pressing and carefully remove the gauge.

NOTE

Only the pad of the gauge must be touched during measurement.
Press down with a force perpendicular to the belt to get an accurate reading.

5. Turn the gauge sideways to see the exact spot where the top of the indicator arm intersects the scale.

NOTE

Take more than one reading to assure repeatable measurements, rotating the crank one-quarter turn after each measurement.

6. Loosen, but do not remove the four, flanged nuts mounting the transmission housing to the motor face.
7. Turn the tension bar nut clockwise to increase tension or counter-clockwise to decrease tension. Tension should be set between 100 and 110 pounds (45 and 50 kilograms).
8. When the tension is correct, use a 3/4-inch socket to torque the three, flanged nuts to 70 ft-lbs (102 Nm).



Do not tighten the flanged nut attaching the end of the tension bar to the housing.

9. Remove tension from the tension bar nut. Torque the fourth flanged nut to 70 ft-lbs (102 Nm).
10. Tighten the tension bar nut to 15 ft-lbs (20 Nm).
11. Install the belt guard.
12. The pump is ready for operation.

Replacing the Belts

NOTE

Replace the belts every 1,500 hours. Replace the belts sooner if they can no longer be tensioned properly.

1. Shut the system down and remove the belt guard.
2. Loosen the four, flanged nuts mounting the transmission housing to the electric motor.
3. Turn the nut on the tension bar counter-clockwise to allow the weldment to rotate so the belts can be removed.
4. Install the four new belts.

NOTE

Replace all four belts at the same time to maintain consistent performance of the drive system.

5. Turn the nut on the tension bar clockwise until there is tension on the belts.
6. Adjust the belt tension following the procedure, Tensioning and Aligning the Belt Drive.

5.10 Pressure Loading Tool Maintenance Kit

Use the following procedure to install the pressure loading tool maintenance kit.

Table 5-6
Pressure Loading Tool Maintenance Kit
72185442

Part Number	Component	Main Assembly
72185450	Backup ring, oil seal	Pressure Loading Tool Assembly
72185458	Oil seal	
10074813	O-ring	
20434082	O-ring	
72185466	Backup ring	
20487868	Loctite 242	
49832199	JL-M anti-seize	

1. Using two 7/8-inch combination wrenches, loosen and remove the four cap nuts and remove the four tie rod extensions.
2. Remove the fill plug from the piston and drain the transmission fluid. Discard the used transmission fluid.

Figure 5-22: Pressure Loading Tool Disassembly

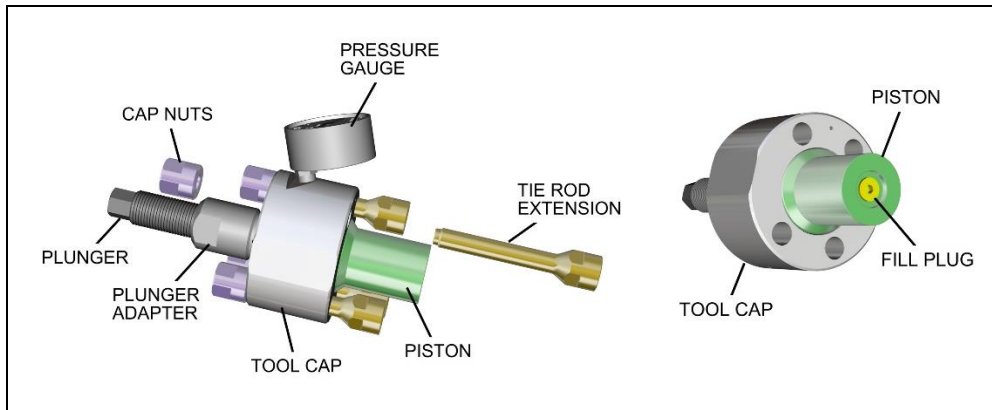

3. Loosen the hex nut and remove the pressure gauge.
4. Remove the piston from the tool cap bore, and remove and discard the existing backup ring and o-ring.
5. Place the plunger hex in a soft jaw vise with the piston bore facing up.

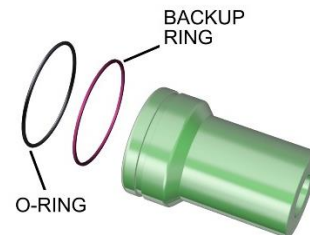
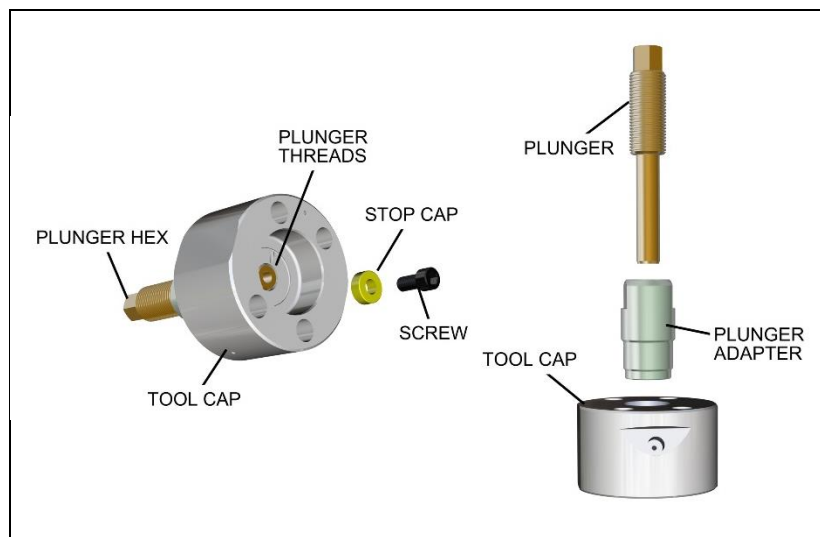
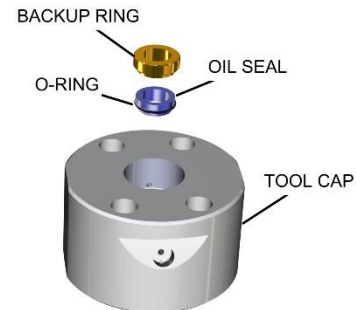

Figure 5-23: Plunger Removal



6. Remove and retain the screw and the stop cap from the bore.

7. Loosen the left hand threads on the plunger adapter and remove the adapter from the tool cap.
8. Remove the plunger from the plunger adapter.
9. Place the tool cap on a workbench with the seal bore facing up.
10. Remove and discard the existing backup ring, oil seal and o-ring.
11. Clean the tool cap and ensure it is free of burrs or any defects.
12. Ensure the new components are clean and place the o-ring on the oil seal. Apply FML-2 food grade grease to the o-ring and insert the seal into the bore in the tool cap until fully seated.
13. Seat the backup ring against the oil seal.



14. Place the tool cap in a soft jaw vise with the oil seal facing up.
15. Inspect the threads on the plunger and plunger adapter. Repair or replace as necessary.
16. Apply JL-M anti-seize grease to the male threads on the plunger and the female threads in the bore of the plunger adapter. Thread the plunger into the adapter.
17. Apply Loctite 242 to the male, left hand threads on the plunger adapter and thread the adapter into the tool cap until fully seated.
18. Using a torque wrench and a 1-1/4-inch crowfoot wrench, torque the adapter to 80 ft-lbs (108 Nm).
19. Remove the tool from the vise.
20. Rotate the plunger clockwise to ensure the plunger is extended through the seal bore and there is sufficient access to the female threads on the end of the plunger.
21. Turn the assembly over and grip the plunger hex in the vise.
22. Place the stop cap on the end of the plunger. Apply Loctite 242 to the left hand threads on the screw, thread the screw through the stop cap and torque to 40 ft-lbs (54 Nm).
23. Remove the tool from the vise, turn the assembly so the piston bore faces up and place the assembly back in the vise.
24. Install the new backup ring and o-ring in the external piston groove.

NOTE

The backup ring is directional shaped. Ensure the o-ring is seated against the radius side of the backup ring.

25. Apply FML-2 food grade grease to the backup ring and the o-ring. Insert the piston in the bore until it is fully seated.
26. Unseat the piston approximately 1/8-inch. This will allow the tool to be slightly overfilled with fluid to aid in evacuating all remaining air from the tool. See Bleeding the Pressure Loading Tool.
27. Install the pressure gauge in the gauge port on the tool cap with the gauge facing the plunger.
28. Ensure the piston is slightly unseated and the plunger is at its fully retracted position. Add automatic transmission fluid through the piston fill port until the fluid is visible in the threads of the piston fill port. Verify the presence of the o-ring on the fill plug and securely fasten the plug to the fill port.
29. Insert the four tie rod extensions through the tool cap bores and apply Pure Goop to the male threads.
30. Install the cap nuts and use a 7/8-inch crowfoot wrench and a 7/8-inch combination wrench to torque the nuts to 50 ft-lbs (68 Nm).

Bleeding the Pressure Loading Tool

This procedure is required after the loading tool has been serviced or after the loss of fluid due to seal leakage. Bleeding the air from the tool on an assembled, but unloaded pump.

1. Lightly seat the four, primary hex nuts on the pump tie rods to remove all endplay. Use a 24 mm combination wrench if necessary.

Figure 5-24: Bleeding the Pressure Loading Tool

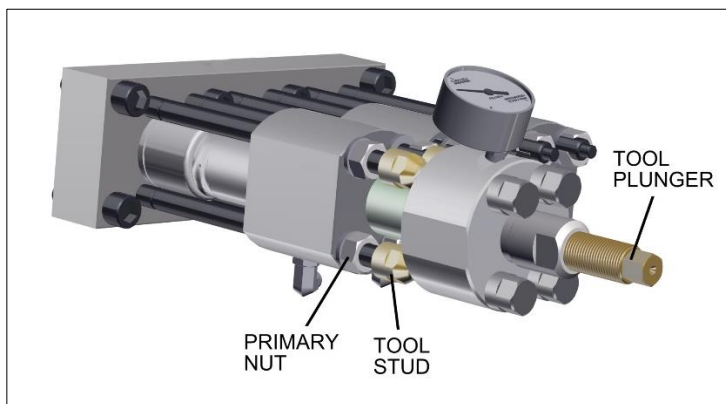

2. Ensure the tool plunger is fully retracted and install the pressure loading tool onto the tie rods by threading the tool studs onto the exposed threads on the tie rods. Alternate between opposite studs to avoid binding.
3. Lightly tighten the four tool studs ensuring the tool piston is seated squarely against the end cap.
4. Use a 22 mm combination wrench to continue tightening the tool studs in a crisscross pattern. Stop tightening when the pressure gauge begins to register pressure.

5. Use a 14 mm combination wrench to loosen the gauge hex nut and bleed off pressure. Bleed excess pressure from the gauge weep port until the gauge reads zero bar. Tighten the hex nut.
6. Continue tightening the tool studs until the tool body or the tool studs bottom out against the tie rods and there is no further increase in gauge pressure when tightening the tool studs.

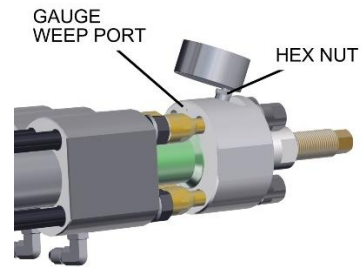

NOTE

Several sequences of tightening the tool studs and bleeding off the pressure may be required.

7. When all air is removed from the tool, tool gauge pressure will increase as the tool plunger is rotated. If this does not occur, repeat Steps 5 and 6 to remove excess air.



SECTION 6

TROUBLESHOOTING

6.1 Overview

The troubleshooting guide will help identify the probable cause of a system malfunction and assist in providing corrective action. To supplement the troubleshooting guide, refer to the troubleshooting illustration at the end of this section. The following symptoms are discussed in this section:

Table 6-1: TRILINE™ Troubleshooting Guide

1. Pump is leaking oil
2. Pump is leaking water
3. Pump is vibrating and/or making noise
4. Pump does not start
5. Pump starts, but immediately shuts down
6. Inlet water gauges are not reading pressure
7. Inlet water filters are clogging too quickly
8. Pump is running too hot
9. Tubing failures occur more frequently with age
10. Pump does not produce the desired pressure

Table 6-2: Short Component Life Guide

1. Dynamic seal
2. Dynamic seal carrier
3. Inlet check valve
4. Discharge check valve
5. Plunger

6.2 Troubleshooting Guide

Listen to the machine and observe it in operation. Learn to recognize the normal sounds and operating conditions of the system. Weep holes provide an outlet for high pressure water in case of seal failure and can help identify problems. Carefully define the symptom of the problem. Locate the symptom on the troubleshooting guide that most closely corresponds to the problem.

If the symptoms in the guide do not correspond to the malfunction, or if the problem is not resolved by the recommended corrective action, contact the KMT Customer Service Department for assistance.

Table 6-1
TRILINE™ Troubleshooting Guide

	Malfunction	Indication	Comments
1.	Pump is leaking oil	Worn seals to include piston rod seals, input shaft seal, rear crankcase cover o-ring and dip stick o-ring	Replace seals as necessary.
		Seals were installed without proper assembly tools	Install new seals using proper tooling.
		Worn or scratched piston rod, cracked crankcase or loose dip stick	Replace as necessary.
2.	Pump is leaking water	High pressure water leaks	Refer to the illustrated guide at the end of this section.
		Low pressure water leaks	Tighten fittings or replace o-rings.



Table 6-1
TRILINE™ Troubleshooting Guide

	Malfunction	Indication	Comments
3.	Pump is vibrating and/or making noise	Missing or worn anti-vibration mat	Install the pump on an anti-vibration mat.
		Replace the existing anti-vibration mat.	
		Improper belt tension or failed belts	Properly adjust the belt tension. See Section 5, Tensioning and Aligning the Belt Drive.
		Replace the belts. See Section 5, Replacing the Belts.	
		Dynamic seal failure	Install a Minor Maintenance Kit. See Section 5.
		Check valve failure	Install a Minor Maintenance Kit. See Section 5.
		Crankcase failure	Replace the crankcase.
		Incorrect motor rotation	Check motor rotation and correct if necessary.
		Loss of electrical power leg	Verify incoming power is on all three legs.
Check the wiring and fuses.			
4.	Pump does not start	Pump is not wired	Verify the customer-supplied service disconnect is on and all fuses are properly sized and functional.
			Verify the motor starter disconnect is turned on.
			Check for loose wiring and correct if necessary.
		Tripped circuit breaker in control box.	Reset circuit breaker.



Table 6-1
TRILINE™ Troubleshooting Guide

Malfunction		Indication	Comments
5.	Pump starts, but immediately shuts down	Shaft spins slowly or not at all	Replace the crankcase.
		Motor overload shutdown has been tripped	Identify the source of the overload and remedy the problem. Reset the overload.
6.	Inlet water gauges are not reading pressure	Inlet water supply is not on or supply pressure is insufficient	Turn water on.
			Inspect water supply pressure.
		Failed pressure gauges	Replace gauges.
		Inlet water solenoid valve is not opening	Verify an open signal is being sent to the valve.
			Check wiring and tighten or replace as necessary.
			Check the circuit breakers/fuses.
		Obstructed or kinked gauge line	Reposition the line or replace if damaged.
Obstructed gauge snubber	Remove obstruction.		
7.	Inlet water filters are clogging too quickly	Missing or clogged inlet water pre-filter	Install or replace the pre-filter.
		Filter element order is reversed	Correct the order of the filters. The correct filter element order is indicated on the pump frame.
		Improper inlet water plumbing material	Only PVC, copper or rubber hoses should be used between the inlet water source and the machine.

Table 6-1
TRILINE™ Troubleshooting Guide

	Malfunction	Indication	Comments
<p>8.</p>	<p>Pump is running too hot</p>	<p>Failed inlet check valve</p>	<p>Install a Minor Maintenance Kit. See Section 5.</p>
		<p>Failed discharge check valve</p>	<p>Install a Minor Maintenance Kit. See Section 5.</p>
		<p>Failed dynamic seal</p>	<p>Install a Minor Maintenance Kit. See Section 5.</p>
		<p>Low oil level in crankcase</p>	<p>Add or replace oil with correct oil. See Sec 7, Specifications.</p>
		<p>Old or bad oil in crankcase</p>	
		<p>Blocked or kinked cooling water hose</p>	<p>Reposition the hose or replace if necessary.</p>
		<p>Air temperature is above specified limit</p>	<p>Call KMT Technical Services.</p>
		<p>Incorrect weight oil for elevated ambient temperature</p>	
<p>9.</p>	<p>Tubing failures occur more frequently with age</p> <p><i>Frequency of low pressure piercing will shorten tubing life</i></p>	<p>Use of incorrect pressure rated tubing</p>	<p>High pressure tubing and fittings must be rated for 60,000 psi (4,137 bar).</p>
		<p>High pressure tubing length is causing ‘standing pressure spikes’</p>	<p>When transporting high pressure water over long distances, tubing and fittings with an outside diameter of 9/16-inch are recommended.</p>



Table 6-1
TRILINE™ Troubleshooting Guide

	Malfunction	Indication	Comments
10.	Pump does not produce the desired pressure	Belts are slipping or have failed (broken or stretched)	Replace the belts; see Section 5, Replacing the Belts.
			Check belt tension and adjust as required, see Section 5, Tensioning and Aligning the Belt Drive.
			Check torque on pulley bolts; see Section 5, Tensioning and Aligning the Belt Drive.
			Check pulley and replace if necessary.
		Orifice is incorrectly sized or damaged Too many orifices of a smaller size are being used	Replace with correctly sized orifice(s). See Section 7, Specifications.
		Insufficient supply air pressure	Check air source. Check hoses and fittings for leaks.
		Insufficient supply water pressure or volume	Check flow rate and pressure of supply water source and filtration system if applicable. Check hoses and fittings for leaks or kinks.
		Failed inlet check valve	Install a Minor Maintenance Kit. See Section 5.
		Failed discharge check valve	Install a Minor Maintenance Kit. See Section 5.
		Damaged check valve body	Install a Major Maintenance Kit. See Section 5.



Table 6-1
TRILINE™ Troubleshooting Guide

Malfunction	Indication	Comments
Pump does not produce the desired pressure, continued	Failed dynamic seal <i>May be an indication of a failed plunger, improper tie rod loading, elevated inlet water temperature or lack of cooling water due to clogged cooling ports.</i>	Inspect plunger and dynamic seal carrier to determine if repairs require a Minor or a Major Maintenance Kit. See Section 5.
	Leaking high pressure cylinder	Inspect the cylinder(s) for cracks. If detected, install a Major Maintenance Kit. See Section 5.
		Inspect the contact surfaces on the dynamic seal carrier and the check valve body for spalling, erosion or damage. If detected, install a Major Maintenance Kit. See Section 5.
	Failed high pressure tubing and/or connection(s)	Check high pressure connections for proper installation and torque.
		Check tubing and fittings for cracks and replace as necessary.
		Check tubing around high pressure connections for deformation and replace tubing as necessary.
	Clogged inlet water filters	Replace filters. See Section 5, Low Pressure Filter Maintenance.
	Failed or improperly calibrated high pressure water gauge	Recalibrate the gauge.
Replace the gauge.		
Excessive tubing length between the pump and the pressure gauge	Call KMT Technical Services.	



Table 6-1
TRILINE™ Troubleshooting Guide

Malfunction	Indication	Comments
Pump does not produce the desired pressure, continued	Damaged low pressure water hose or loose fittings	Inspect hoses and fittings and replace as necessary.
	Improper pulley ratio for power frequency	Verify required pulley size for input power.
	Missing 3-phase power leg	Verify incoming power is on all three legs.
	Worn or dirty pressure control valve poppet and seat	Clean poppet and seat and check for damage. Install a Minor Maintenance Kit. See Section 5.
		Install a Pressure Control Valve Maintenance Kit. See Section 5.
		Ensure proper plumbing of the drain line for the PCV.
	Inlet water supply solenoid valve failure	Replace solenoid valve.
		Check for loose wiring and tighten wire fittings if necessary.
		Check breaker in electrical control box.
	2-way air valve failure (air to pressure control valve)	Replace valve.
		Check for loose wiring and tighten wire fittings if necessary.
		Check breaker in electrical control box.
	2-way air valve override switch is improperly positioned	Position the override switch in 'automatic' mode.

Short Component Life

- Ensure all recommended service and maintenance procedures
- Install all kit components at the same time, do not replace components individually
- Verify all utility and pump installation requirements have been met

Common causes for excessively short component life include:

- Poor inlet water quality
- Low inlet water pressure
- Improperly plumbed drain line
- Improperly loaded tie rod(s)

Table 6-2
Short Component Life Guide

Malfunction		Indication	Comments
1.	Dynamic seal	Worn or damaged plungers	Install a Major Maintenance Kit. See Section 5.
		Worn or damaged check valve assembly	Install a Minor Maintenance Kit. See Section 5.
		Worn or damaged dynamic seal carrier	Install a Major Maintenance Kit. See Section 5.
		Inlet water temperature is too high or too low	Call KMT Technical Services.
2.	Dynamic seal carrier	Worn or damaged plungers	Install a Major Maintenance Kit. See Section 5.
		Incorrect seal installation	Reinstall the dynamic seals.
		Cooling ports in dynamic seal carrier are clogged	Clean cooling ports.
		Insufficient cooling water flow	Inspect water filters and inlet water supply pressure.

Table 6-2
Short Component Life Guide

Malfunction		Indication	Comments
3.	Inlet check valve	Pinched inlet poppet	Install a Minor Maintenance Kit.
		Broken compression spring	Install a Minor Maintenance Kit.
		Worn filler tube or sleeve	Install a Minor Maintenance Kit.
		Improper use of lubricants on check valve surfaces	Clean and reinstall the check valve.
		Dirt or debris between the inlet poppet and the seat	Clean the debris and inspect the poppet and seat for damage. If damage is detected, install a Minor Maintenance Kit.
4.	Discharge check valve	Broken compression spring	Install a Minor Maintenance Kit. See Section 5.
		Dirt or debris between the discharge poppet and the seat	Clean the debris and inspect the poppet and seat for damage. If damage is detected, install a Minor Maintenance Kit.
5.	Plunger damage	Worn or damaged dynamic seal carrier	Install a Major Maintenance Kit. See Section 5.
		Incorrect dynamic seal installation, seals are reversed	Install a Minor Maintenance Kit. See Section 5.
		Cooling ports in dynamic seal carrier are clogged	Clean cooling ports.
		Insufficient cooling water flow in subplate adapter and dynamic seal carrier	Inspect water filters and inlet supply water pressure.

Troubleshooting Illustration

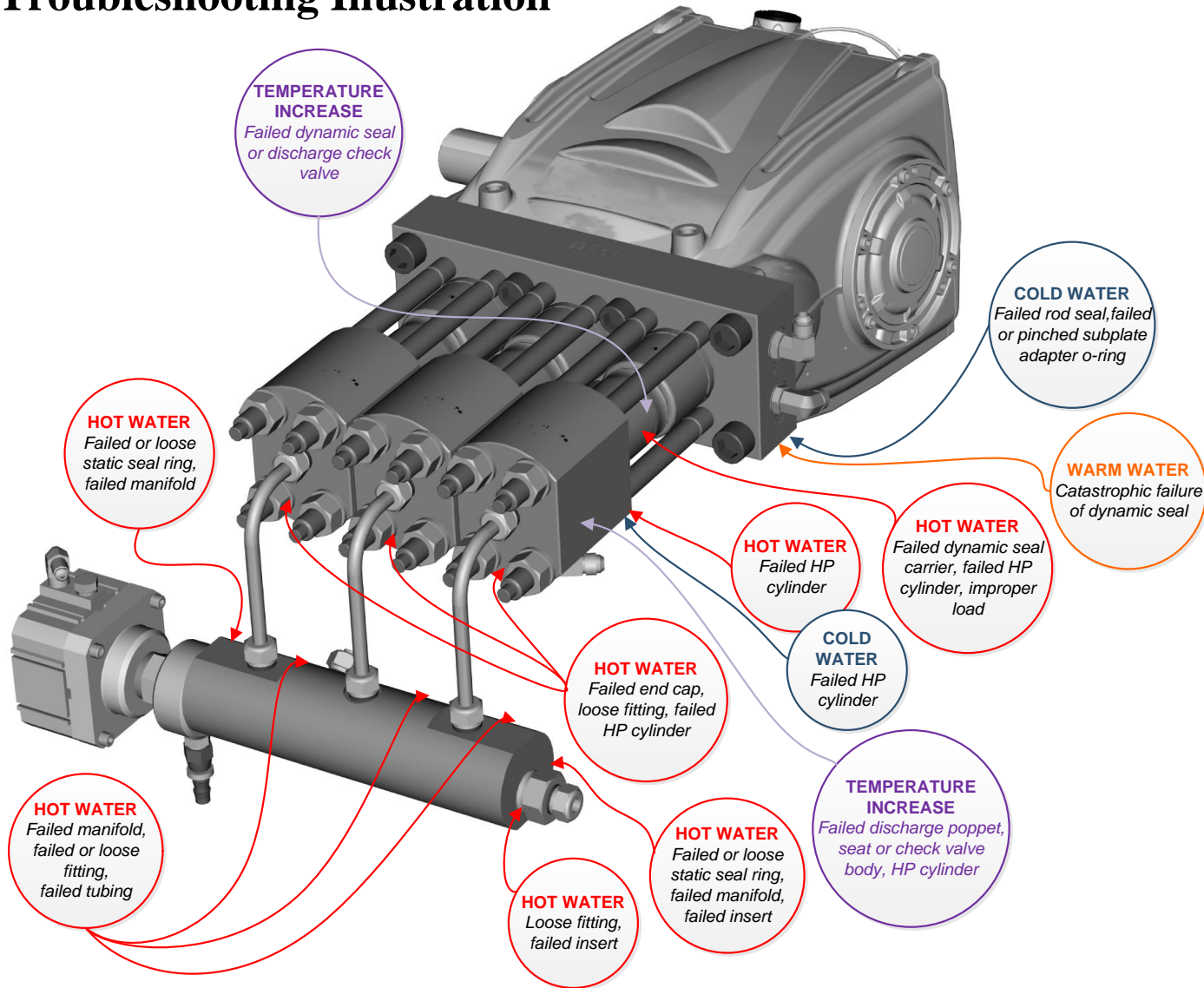



SECTION 7 SPECIFICATIONS

7.1 Overview

Comprehensive listing of specifications for the TRILINE™ pump are provided in this section.

**Table 7-1
TRILINE™**

Motor Horsepower Rating		Maximum Operating Pressure	Water Volume	Maximum Single Orifice Diameter (at full pressure)	Motor Speed
HP	Kw				
30	22	55,000 psi (3,792 bar)*	0.84 gpm (3.18 L/min)	0.012" (0.30 mm)	720 rpm

**Note:* Maximum pressure with cutting head valve open is 55,000 psi (3,792 bar). Maximum pressure with cutting head valve closed is 60,000 psi (4,137 bar).

7.2 Installation Specifications

Installation location	Indoors
Air borne dust/contaminants	Minimal
Ambient temperature range	45-104 ° F (7-40° C)
Sound level with doors	84 dB(A)
Sound level without doors	86 dB(A)

Service Connections	Connection
Inlet water (to filters)	1/2" NPT
Drain (from pressure control valve)	1/2" NPT
Air inlet	1/4" NPT
HP water outlet	3/8" HP

Equipment Dimensions	Length	Width	Height	Weight
30 HP	41.0" (1041 mm)	43.0" (1092 mm)	50.0" (1270 mm)	1125 lbs (510 Kg)

7.3 Pump Specifications

Minimum inlet water flow rate and pressure	2.0 gpm @ 57 psi (7.5 L/min @ 3.9 bar)
<i>Systems should be sized for 150% of the pump capacity</i>	
Low inlet water pressure switch threshold	15 psi (1 bar)
Required inlet water temperature range	55°-70° F (12.7°-21.0° C)
<i>Water temperatures exceeding this range will result in seal life degradation. If seal life becomes unacceptable, the addition of a chiller is recommended.</i>	
Drain water temperature and flow rate	212° F (100° C) at 0.9 gpm (3.4 L/min)
Output pressure range (dual pressure units)	1,000-55,000 psi (69-3,792 bar)
Crankcase reservoir capacity	1.2 gal (4.54 liter)
Recommended oil	Shell Morlina 100 Hydraulic Oil (ISO 100)
<i>When operating in an ambient temperature greater than 86° F (30° C), a heavier oil is recommended</i>	Other manufacturer's equivalents can be used
Motor type	TEFC (Totally Enclosed Fan Cooled)

NOTE

See nameplate for machine specific ampacity and power voltage requirements.

Plant Air

The facility compressed air connection should provide clean, dry air regulated to between 90 and 120 psi (6.2 and 8.3 bar).

The following table provides specifications for each ISO air quality classification. KMT recommends adherence to Quality Class 4.

Table 7-2
ISO Air Quality Classifications

ISO Quality Class	Maximum Particle Size (microns)	Maximum Pressure Dew Point (water @ 100 psi)	Maximum Oil Content (Mg/m ³)
1	0.1	-94° F (-60° C)	0.01
2	1	-40° F (-40° C)	0.1
3	5	-4° F (-20° C)	1
4	15	+38° F (+3° C)	5

Table 7-2
ISO Air Quality Classifications

ISO Quality Class	Maximum Particle Size (microns)	Maximum Pressure Dew Point (water @ 100 psi)	Maximum Oil Content (Mg/m ³)
5	40	+45° F (+7° C)	25
6	--	+50° F (+10° C)	--

7.4 Water Quality Standards

The quality of the inlet cutting water supply is one of the most important factors affecting component life and performance. Water treatment requirements can be determined by a water analysis.



Due to its aggressive nature, KMT does not recommend using deionized water in our pumps.

The cutting water supply must meet the following standards. A high concentration of dissolved solids, especially calcium, silica and chlorides will affect high pressure component life.

Table 11-1
Water Quality Standards

Constituent (mg/l or ppm)	Minimum Requirement	Better	Best
Alkalinity	50	25	10
Calcium	25	5	0.5
Chloride	100	15	1
Free Chlorine	1	1	0.05
Iron	0.2	0.1	0.01
Magnesium as Mg	0.5	0.1	0.1
Manganese as Mn	0.1	0.1	0.1
Nitrate	25	25	10
Silica	15	10	1
Sodium	50	10	1
Sulfate	25	25	1
TDS*	200	100	35**



**Table 11-1
Water Quality Standards**

Constituent (mg/l or ppm)	Minimum Requirement	Better	Best
Total Hardness	25	10	1
pH	6.5-8.5	6.5-8.5	6.5-8.5
Turbidity (NTU)	5	5	1

* *Note:* Total dissolved solids

***Note:* Do not reduce the TDS beyond this amount or the water will be too aggressive.

**Table 11-2
Water Impurities**

Constituent	Chemical Formula	Comments
Alkalinity	Bicarbonate (HCO ₃) Carbonate (CO ₃) Hydrate (OH), expressed as CaCO ₃	Acid neutralizing capacity of water. Foaming and carryover of solids, causes embrittlement of steel, can produce CO ₂ , a source of corrosion.
Calcium	Ca	When dissolved makes water hard; contributes to the formation of scale.
Chloride	Cl	Adds to solid content and increases corrosive character of water; in relative percentage presence with oxygen induces stress corrosion cracking.
Free Chlorine	Cl ₂	Oxidizing agent; can attack elastomeric seals and damage reverse osmosis (RO) membranes.
Iron	Fe ⁺⁺ (ferrous) Fe ⁺⁺⁺ (ferric)	Discolors water or precipitation; source of scale and erosion.
Magnesium as Mg		When dissolved makes water hard; contributes to the formation of scale.
Manganese as Mn	Mn ⁺⁺	Discolors water or precipitation; source of scale and erosion.
Nitrate	NO ₃	Adds to solid content; effect is not generally significant industrially.
Silica	SiO ₂	Causes scale
Sodium	Na	Found naturally; introduced to water in the ion exchange water softening process.



Table 11-2
Water Impurities

Constituent	Chemical Formula	Comments
Sulfate	SO ₄	Adds to solid content; combines with calcium to form calcium sulfate scale.
TDS		Measure of the total amount of dissolved matter in water.
Total Hardness	CaCO ₃	Sum of all hardness constituents in water; typically expressed as their equivalent concentration of calcium carbonate; primarily due to calcium and magnesium in solution, but may include small amounts of metal. Carbonate hardness is usually due to magnesium and calcium bicarbonate; non-carbonate hardness is due to sulfates and chlorides.
pH		Intensity of the acidic or alkaline solids in water; pH scale runs from 0, highly acidic, to 14, highly alkaline; with 7 being neutral.

SECTION 8

PARTS LIST

8.1 Overview

This section contains a comprehensive list of all replacement parts and maintenance tools for the TRILINE™ direct drive pump. To facilitate the ordering of replacement parts, item numbers in each table correspond to the identifying numbers in the accompanying figures.

Use the following information to contact the Customer Service Department at KMT Waterjet Systems.

USA

Customer Service Department
KMT Waterjet Systems
PO Box 231
635 West 12th Street
Baxter Springs, KS 66713-0231
USA

Phone (800) 826-9274
Fax (620) 856-2242
Email wj.service@kmtwaterjet.com
wj.parts@kmtwaterjet.com

Europe

Spare Parts Manager
KMT Waterjet Systems GmbH
Hohe Strasse 4-6
D-61231 Bad Nauheim
Germany

Phone +49-6032-997-0
Fax +49-6032-997-270
Email order.spares@kmt-waterjet.com

8.2 Index

Part lists are arranged in the following sequence:

Parts List Index

Table	Description	Part Number	Page	Table	Description	Part Number	Page
8-1	Minor Maintenance Kit	72185099	8-3	8-5	Pressure Loading Tool	72185434	8-10
8-2	Major Maintenance Kit	72185284	8-5		Spare Parts Kit	72185442	8-10
8-3	Poppet/Seat Assembly	72185234	8-8	8-6	Tool Kits and Miscellaneous		8-11
8-4	Pressure Control Valve Maintenance Kit	72185333	8-9				

Table 8-1
Minor Maintenance Kit
72185099

Item	Part Number	Description	Quantity	Item	Part Number	Description	Quantity
1	72185177	Dynamic Seal	3	10	204334082	O-Ring	3
2	72185125	Rod Seal	3	11	05122007	O-Ring	3
3	72185133	Inlet Poppet	3	12	20434082	O-Ring	3
4	72185141	Compression Spring	3	13	10074383	O-Ring	3
5	72185149	Sleeve	3	14	72185208	Rod Seal	3
6	72185167	Poppet Guide	3	15	72185226	Retaining Ring	3
7	72185185	Discharge Poppet	3	16	72185234	Poppet/Seat Assembly	1
8	72185192	Poppet Seat	3	17	10149029	320 Grit Paper	1
9	72185200	Compression Spring	3	18	10087385	FML-2 Food Grade Grease	1
				19	49832199	JL-M Anti-seize	1

Figure 8-1: Minor Maintenance Kit

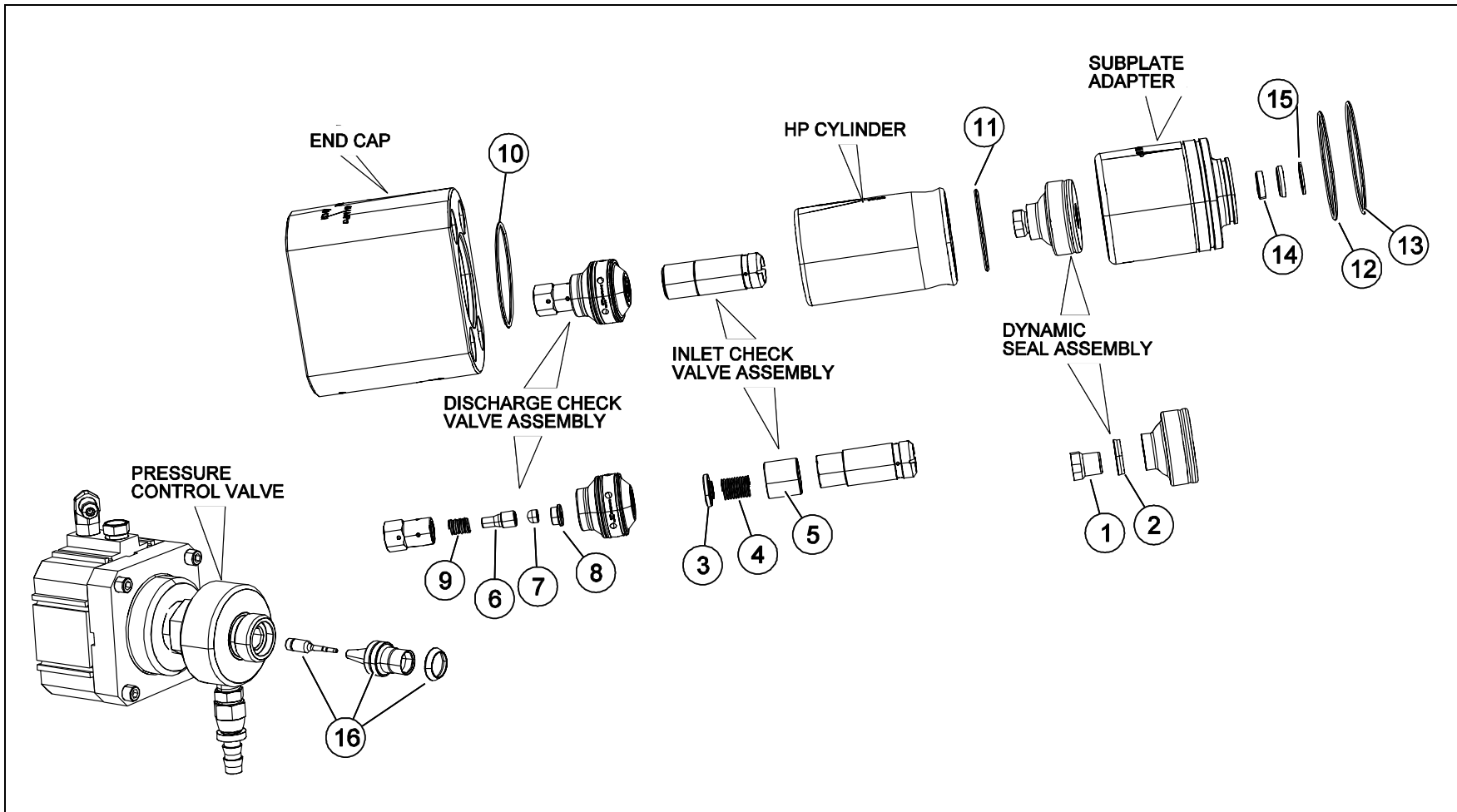

Table 8-2
Major Maintenance Kit
72185284

Item	Part Number	Description	Quantity	Item	Part Number	Description	Quantity
1	72185117	Dynamic Seal	3	14	204334082	O-Ring	3
2	72185125	Rod Seal	3	15	72185325	High Pressure Cylinder	3
3	72185291	Seal Carrier Assembly	3	16	05122007	O-Ring	3
4	72185133	Inlet Poppet	3	17	20434082	O-Ring	3
5	72185141	Compression Spring	3	18	10074383	O-Ring	3
6	72185149	Sleeve	3	19	72185208	Rod Seal	3
7	72186948	Compression Spring	3	20	72185226	Retaining Ring	3
8	72185167	Poppet Guide	3	21	72186940	Compression Spring	3
9	72185185	Discharge Poppet	3	22	72186914	Plunger Assembly	3
10	72185192	Poppet Seat	3	23	72186890	V-belt Set	1
11	72185200	Compression Spring	3	24	72185234	Poppet/Seat Assembly	1
12	72185307	Valve Body	3	25	10087385	FML-2 Food Grade Grease	1
13	10074383	O-Ring	3	26	49832199	JL-M Anti-seize	1

Figure 8-2: Major Maintenance Kit

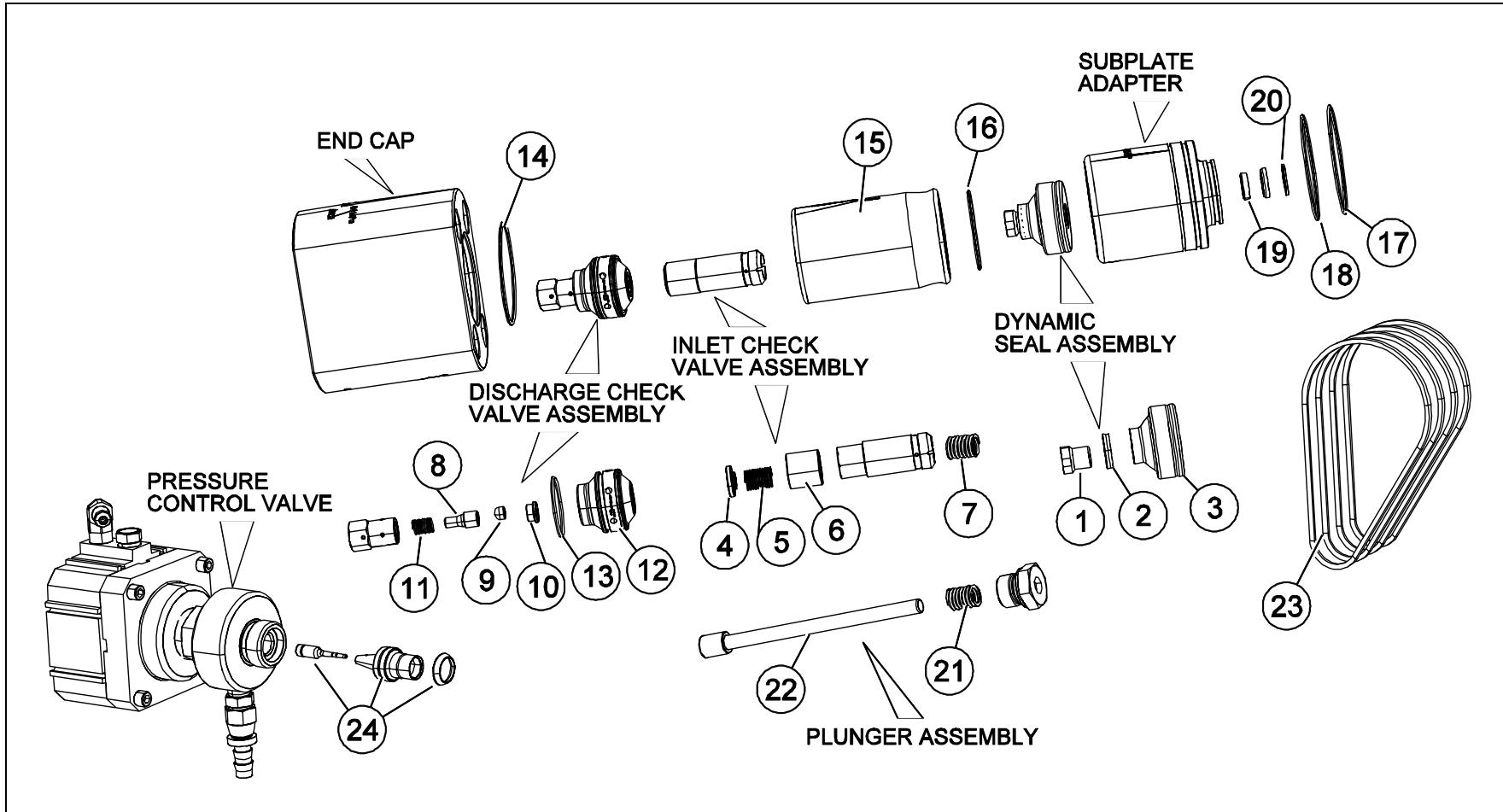

Table 8-3
Poppet/Seat Assembly, Pressure Control Valve
72185234

Item	Part Number	Description	Quantity
1	72185250	Poppet	1
2	72185258	Seat	1
3	72185276	Static Seal Ring	1

Figure 8-3: Poppet/Seat Assembly

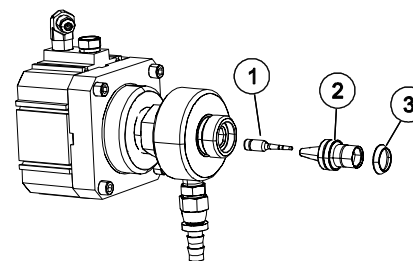

Table 8-4
Pressure Control Valve Maintenance Kit
72185333

Item	Part Number	Description	Quantity
1	72185341	Bearing Assembly	1
2	72185349	Plunger	1
3	72185357	Plunger Seal	1
4	10113884	O-Ring	1
5	72129276	O-Ring	1
6	72129268	O-Ring	1
7	10087385	FML-2 Food Grade Grease	1

Figure 8-5: Pressure Control Valve Maintenance Kit

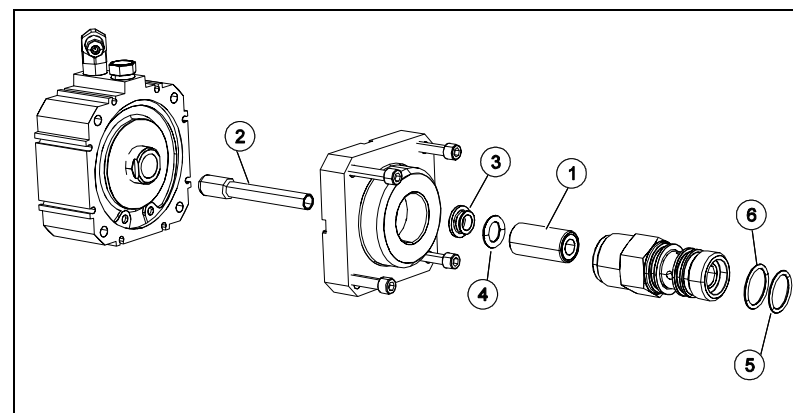

Table 8-5
Pressure Loading Tool
72185434

Item	Part Number	Description	Quantity
	72185434	Pressure Loading Tool	
	72185442	Spare Pats Kit	
1	72185450	Backup Ring, Oil Seal	1
2	72185458	Oil Seal	1
3	10074813	O-Ring	1
4	20434082	O-Ring	1
5	72185466	Backup Ring	1
6	20487868	Loctite 242	1
7	49832199	JL-M Anti-seize	1

Figure 8-6: Spare Parts Kit

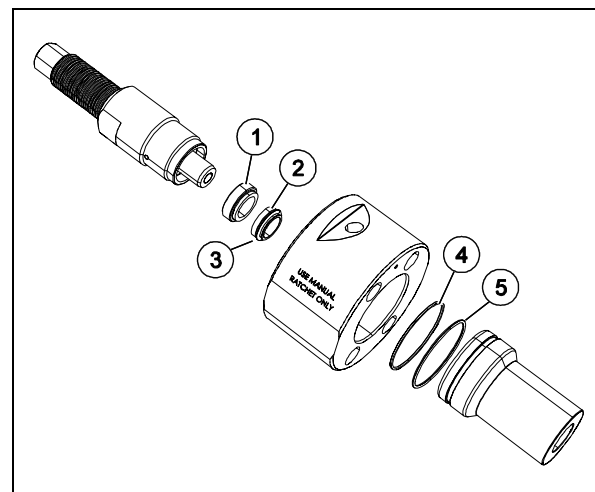

Table 8-6
Tools Kits and Miscellaneous

Item	Part Number	Description	Quantity
	72185375	Pump Tool Kit	
1	72185393	Plunger Nut Tool	1
2	72185400	Rebuild Clamp	1
3	72185408	Belt Tensioner Gauge	1
4	10149052	Glass Pane	1
5	10084440	Pure Goop	1
6	05048681	Medical Alert Card	1
7	49881485	Hex Head Screw	1
8	95277109	Flat Washer	1
9	80101403	Oil Seal Installation Tool, 22.70 x 65MM	1
10	80101395	Oil Seal Installation Tool, 40MM x 28MM	1
	72185492	Bearing Removal/Installation Tool	
	72185076	Fine Filter Element	
	72185083	Coarse Filter Element	

REVISIONS		
NO.	DESCRIPTION	APPROVED

KMT Triline

NOTES:

1. All control conductors shall be 18 awg unless otherwise specified.
2. Soft starter settings are:
 - Ramp up time: 5s
 - Ramp down time: 0s
 - Initial voltage: 40%
3. Overload needs to be set to the FLA of the motor.
4. All protective conductor terminations will be:
ONE wire, ONE termination point.
5. Motor leads need to be wired as shown below:

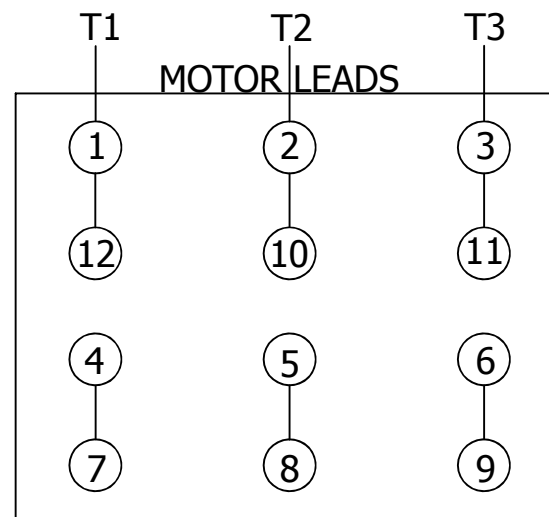

Copyright © 2016 KMT Waterjet Systems All Rights Reserved	PROPRIETARY NOTICE This document contains confidential and trade secret information, is the property of KMT Waterjet Systems, and is given to the receiver in confidence. The receiver by reception and retention of the document accepts the document in confidence and agrees that, except as authorized in writing by KMT Waterjet Systems, it will (1) not use the document on any copy thereof or the confidential or the trade secret information therein; (2) not copy the document (3) not disclose to others either the document or the confidential or trade secret information therein; and (4) upon completion of the need to retain the document, or upon demand return the document, all copies thereof, and all material copied therefrom.	STANDARD TOLERANCES UNLESS OTHERWISE NOTED: ALL DIAMETERS ON COMMON CENTERLINE COAXIAL TO .005 BREAK SHARP EDGES AND CORNERS .015 SURFACE FINISH STANDARD TOLERANCES XX = ±.063 XXX = ±.015 XXXX = ±.005 ANGLE = ±2°	GD&T TO ASME Y14.5M 1994 ALL DIMENSIONS IN INCHES (mm) MATERIAL: FINISH: HEAT TREAT: HARDNESS:	REF. DWG: D. LAWSON 5/11/2016 CHECKED BY & DATE: ENGR. APPROVAL & DATE:	KMT KMT Waterjet	TITLE KMT Triline pump
WARNING ! The export or reexport of this drawing or a product produced by this drawing is subject to U.S. Export Administration regulations and other applicable governmental restrictions or regulations.					KMT KMT Waterjet	DWG. NO. 72187039
NEXT ASSEMBLY					THIRD ANGLE PROJECTION	REV. 0
			SCALE: 1 : 1		TITLE BLOCK REVISION: 2	1 OF 5

REV.	DESCRIPTION	DATE	APPROVED

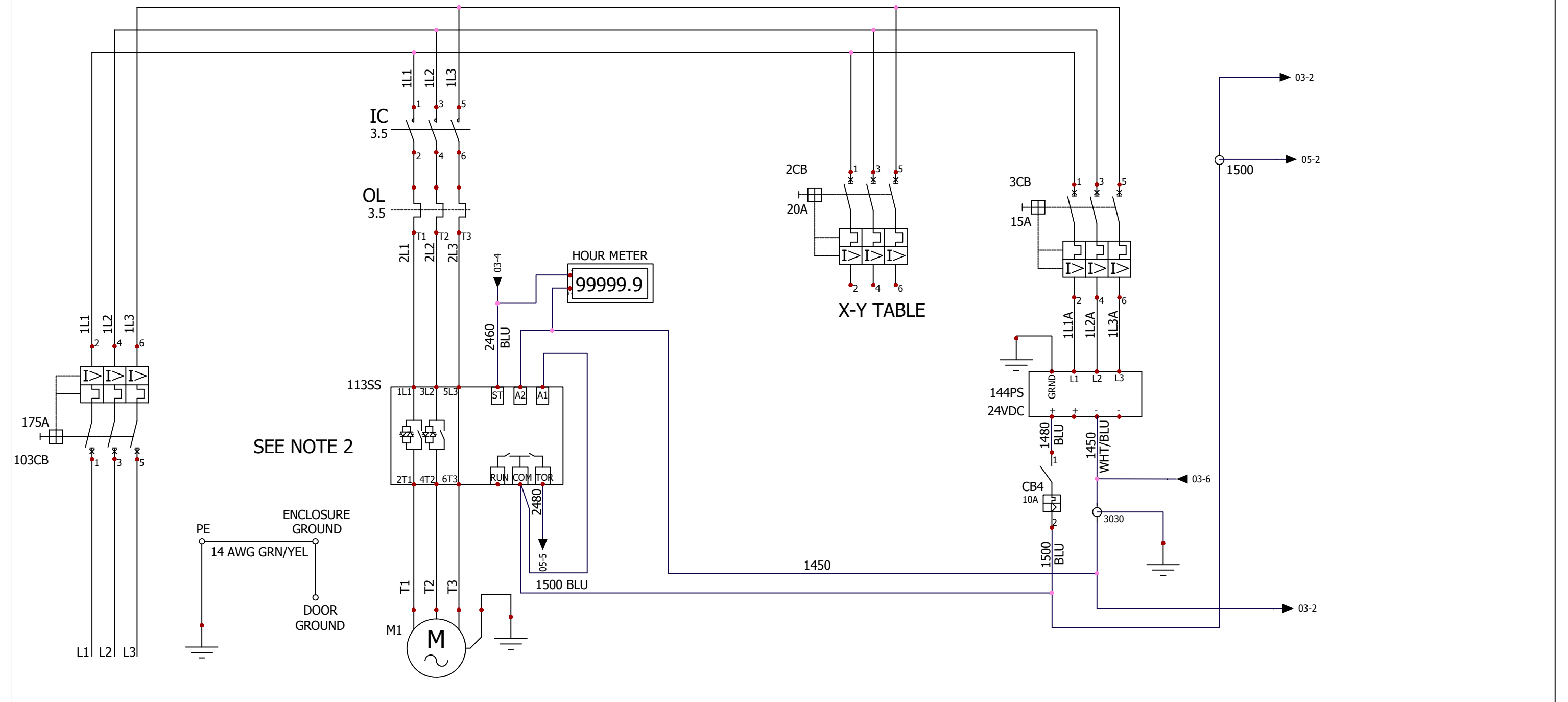

SEE NOTE 2

SEE NOTE 5

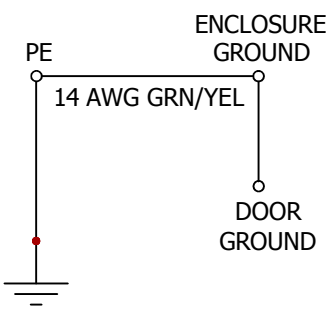

Copyright © 2016 KMT Waterjet Systems All Rights Reserved	PROPRIETARY NOTICE This document contains confidential and trade secret information, is the property of KMT Waterjet Systems, and is given to the receiver in confidence. The receiver by reception and retention of the document accepts the document in confidence and agrees that, except as authorized in writing by KMT Waterjet Systems, it will (1) not use the document on any copy thereof or the confidential or the trade secret information therein; (2) not copy the document (3) not disclose to others either the document or the confidential or trade secret information therein; and (4) upon completion of the need to retain the document, or upon demand return the document, all copies thereof, and all material copied therefrom.	STANDARD TOLERANCES UNLESS OTHERWISE NOTED: ALL DIMETERS ON COMMON CENTERLINE COAXIAL TO .005 BREAK SHARP EDGES AND CORNERS .015 SURFACE FINISH STANDARD TOLERANCES: XX = ±.063 XXX = ±.015 XXXX = ±.005 ANGLE = ±2°	GD&T TO ASME Y14.5M 1994 ALL DIMENSIONS IN INCHES (mm) MATERIAL HEAT TREAT FINISHNESS	REF. DWG D. LAWSON 5/11/2016 CHECKED BY & DATE ENCL. APPROVAL & DATE	KMT KMT Waterjet	TITLE KMT Triline pump
WARNING ! The export or reexport of this drawing or a product produced by this drawing is subject to U.S. Export Administration regulations and other applicable governmental restrictions or regulations.					DWG. NO. 72187039	REV. 0
NEXT ASSEMBLY			SCALE: 1 : 1	TITLE BLOCK REVISION: 2		2 OF 5

REVISIONS			
NO.	DESCRIPTION	DATE	APPROVED

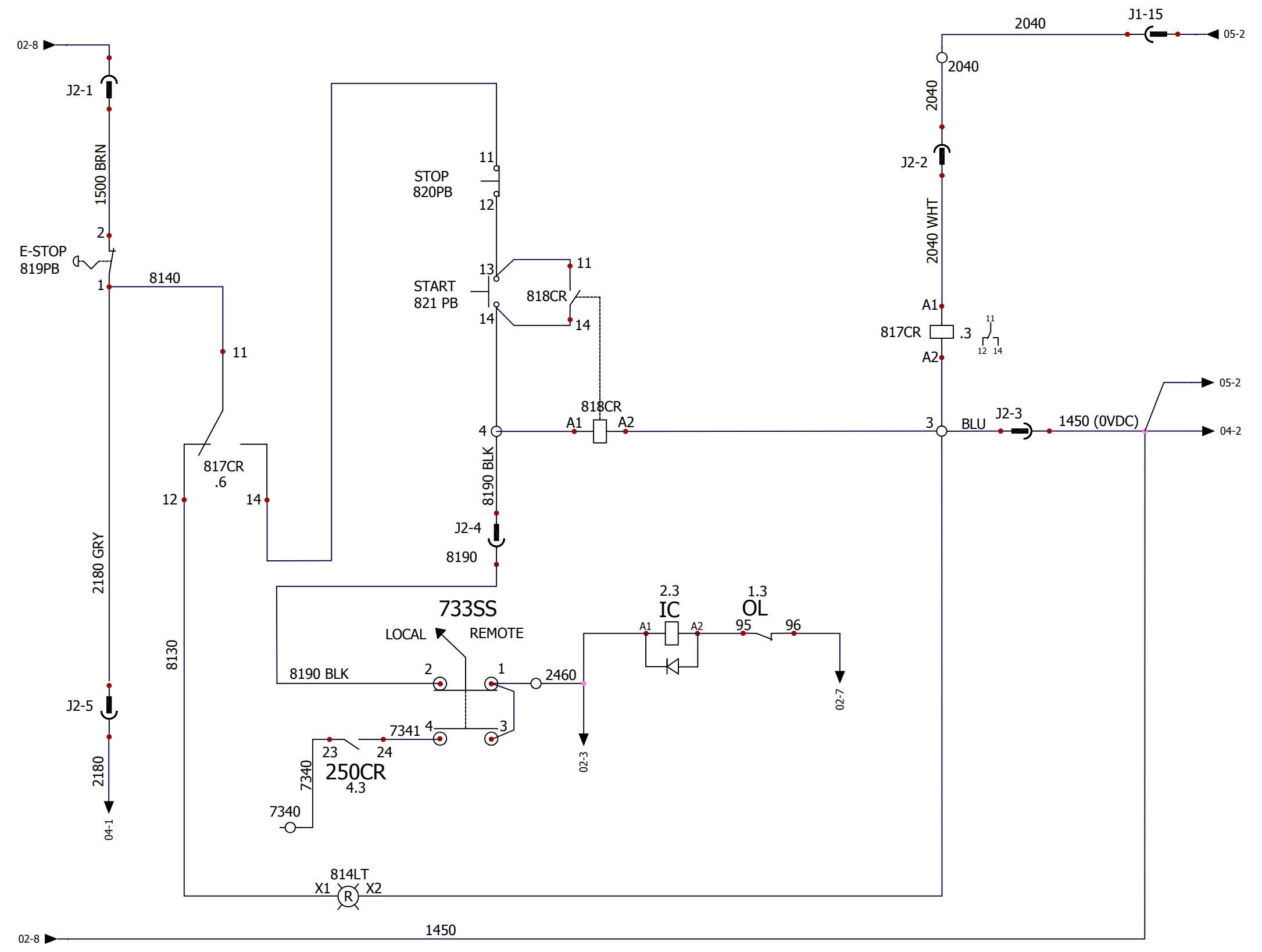

NEXT ASSEMBLY

Copyright © 2016 KMT Waterjet Systems All Rights Reserved	PROPRIETARY NOTICE This document contains confidential and trade secret information, is the property of KMT Waterjet Systems, and is given to the receiver in confidence. The receiver by reception and retention of the document accepts the document in confidence and agrees that, except as authorized in writing by KMT Waterjet Systems, it will (1) not use the document on any copy thereof or the confidential or the trade secret information therein; (2) not copy the document; (3) not disclose to others either the document or the confidential or trade secret information therein; and (4) upon completion of the need to retain the document, or upon demand return the document, all copies thereof, and all material copied therefrom.	STANDARD TOLERANCES UNLESS OTHERWISE NOTED: ALL DIMENSIONS ON COMMON CENTERLINE COAXIAL TO .005 BREAK SHARP EDGES AND CORNERS .015 SURFACE FINISH STANDARD TOLERANCES XX = ±.063 XXX = ±.015 XXXX = ±.005 ANGLE = ±2°	GD&T TO ASME Y14.5M 1994 REF. DIM. D. LAWSON 5/11/2016 CHECKED BY & DATE ENCL. APPROVAL & DATE	KMT KMT Waterjet	KMT Triline pump DWG. NO. 72187039 REV. 0
WARNING ! The export or reexport of this drawing or a product produced by this drawing is subject to U.S. Export Administration regulations and other applicable governmental restrictions or regulations.				SCALE: 1 : 1	TITLE BLOCK REVISION: 2 3 OF 5

DWG. NO. 72187039		REV. 4	REV. 0
NO.	DESCRIPTION	DATE	APPROVED

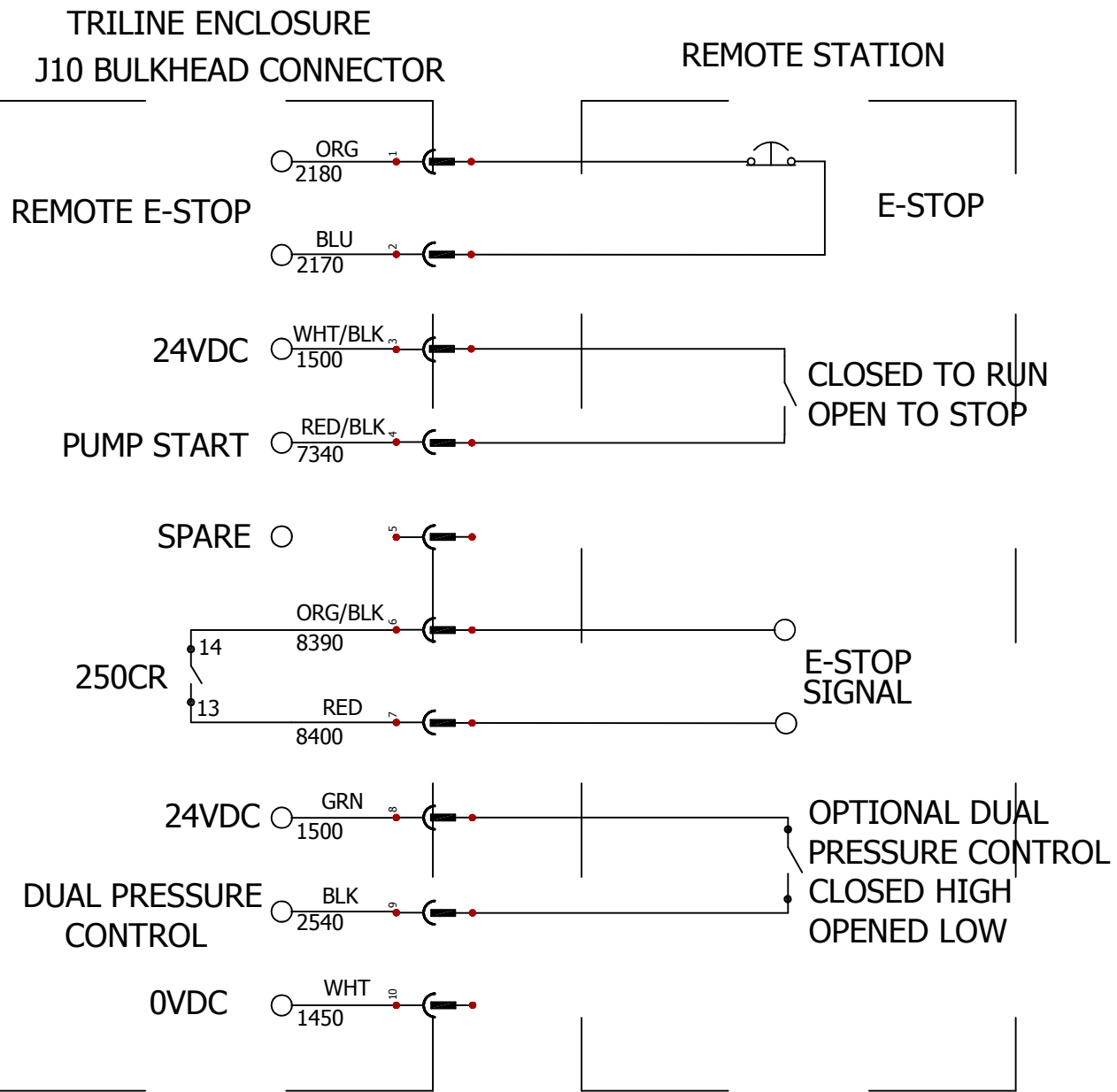
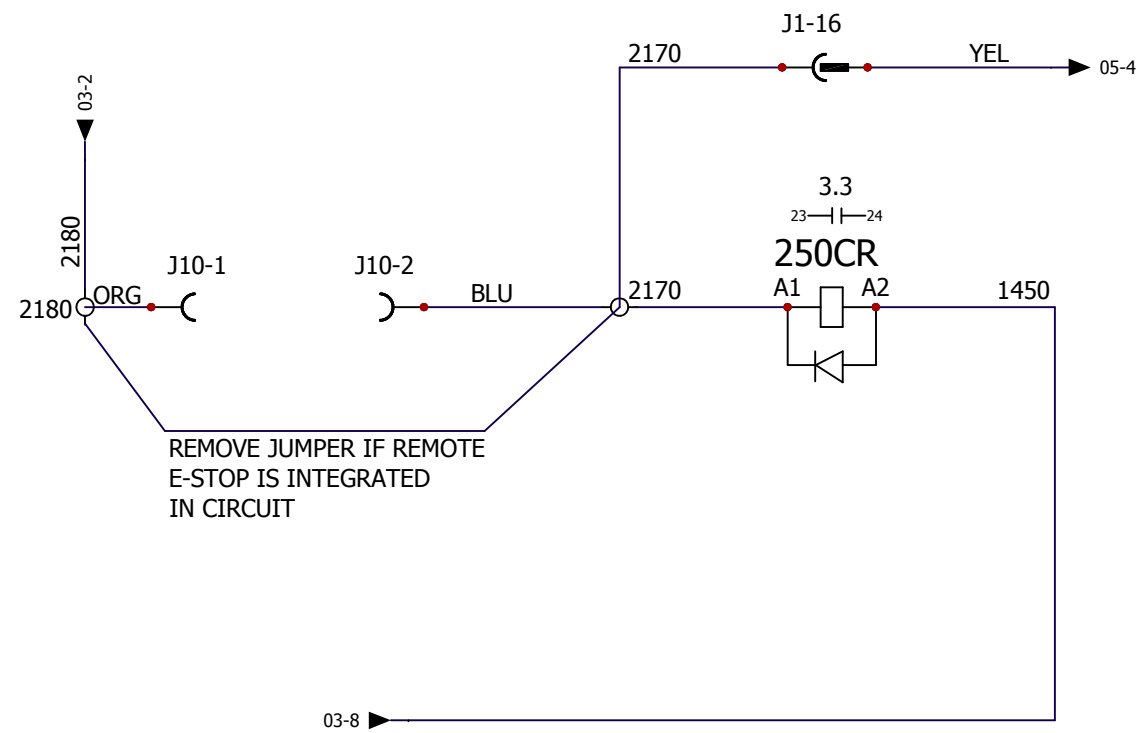

Copyright © 2016 KMT Waterjet Systems All Rights Reserved WARNING ! The export or reexport of this drawing or a product produced by this drawing is subject to U.S. Export Administration regulations and other applicable governmental restrictions or regulations.	PROPRIETARY NOTICE This document contains confidential and trade secret information, is the property of KMT Waterjet Systems, and is given to the receiver in confidence. The receiver by reception and retention of the document accepts the document in confidence and agrees that, except as authorized in writing by KMT Waterjet Systems, it will (1) not use the document on any copy thereof or the confidential or the trade secret information therein; (2) not copy the document; (3) not disclose to others either the document or the confidential or trade secret information therein; and (4) upon completion of the need to retain the document, or upon demand return the document, all copies thereof, and all material copied therefrom.	STANDARD TOLERANCES UNLESS OTHERWISE NOTED: ALL DIAMETERS ON COMMON CENTERLINE COAXIAL TO .005 BREAK SHARP EDGES AND CORNERS .015 SURFACE FINISH STANDARD TOLERANCES .XX = ±.063 .XXX = ±.015 .XXXX = ±.005 ANGLE = ±2°	GD&T TO ASME Y14.5M 1994 ALL DIMENSIONS IN INCHES (mm) MATERIAL HEAT TREAT FINISHNESS	REF. DWG. D. LAWSON 5/11/2016 <small>DESIGNED BY & DATE</small>	 KMT Triline pump
				<small>ENG. APPROVAL & DATE</small>	

NEXT ASSEMBLY

REVISIONS			
NO.	DESCRIPTION	DATE	APPROVED

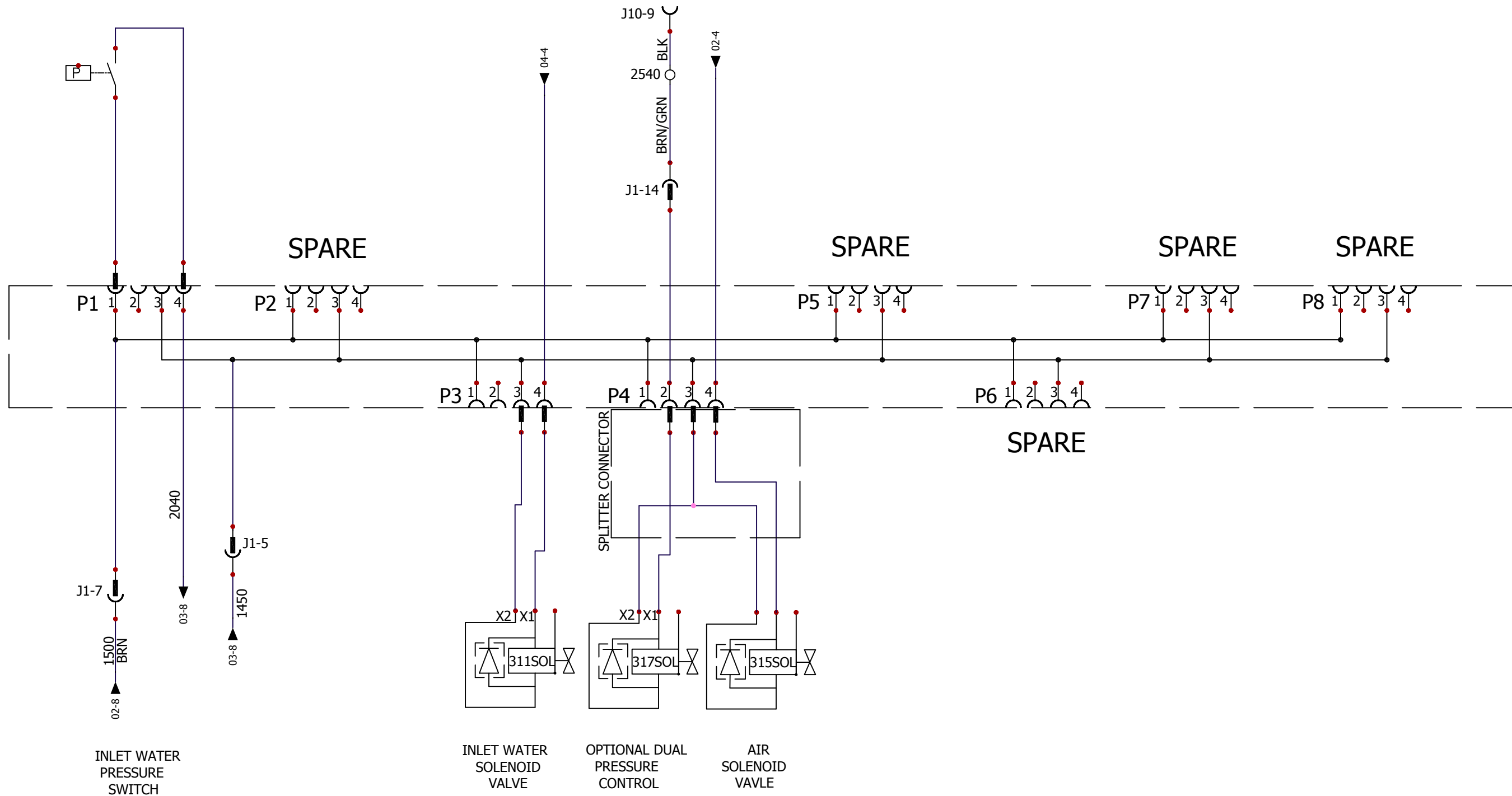

NEXT ASSEMBLY

<p>Copyright © 2016 KMT Waterjet Systems All Rights Reserved</p> <p>WARNING ! The export or reexport of this drawing or a product produced by this drawing is subject to U.S. Export Administration regulations and other applicable governmental restrictions or regulations.</p>	<p>PROPRIETARY NOTICE</p> <p>This document contains confidential and trade secret information, is the property of KMT Waterjet Systems, and is given to the receiver in confidence. The receiver by reception and retention of the document accepts the document in confidence and agrees that, except as authorized in writing by KMT Waterjet Systems, it will (1) not use the document on any copy thereof or the confidential or the trade secret information therein; (2) not copy the document (3) not disclose to others either the document or the confidential or trade secret information therein; and (4) upon completion of the need to retain the document, or upon demand return the document, all copies thereof, and all material copied therefrom.</p>	<p>STANDARD TOLERANCES</p> <p>UNLESS OTHERWISE NOTED: ALL DIAMETERS ON COMMON CENTERLINE COAXIAL TO .005 BREAK SHARP EDGES AND CORNERS .015 SURFACE FINISH STANDARD TOLERANCES XX = ±.063 XXX = ±.015 XXXX = ±.005 ANGLE = ±2°</p>	<p>GD&T TO ASME Y14.5M 1994</p> <p>ALL DIMENSIONS IN INCHES (mm)</p> <p>MATERIAL</p> <p>HEAT TREAT</p> <p>FINISHNESS</p>	<p>REF. DWG.</p> <p>D. LAWSON 5/11/2016</p> <p>DESIGNED BY & DATE</p>	<p>KMT KMT Waterjet</p>	<p>TITLE</p> <p>KMT Triline pump</p>
				<p>ENG. APPROVAL & DATE</p>		



MATERIAL SAFETY DATA SHEET

PURE GOOP™

November 2003

1. PRODUCT IDENTIFICATION

PURE GOOP: Thread lubricant

Manufactured by:
Swagelok Company
29500 Solon Road
Solon, Ohio USA 44139
Tel: (440) 248-4600
Fax: (440) 349-5970

Emergency Contact:
Chemtrec (800) 424-9300

2. INGREDIENTS

Ingredients	CAS #	WT%	PEL
Polychlorotrifluoroethylene	9002-83-9	75-85	Not Available
Polytetrafluoroethylene	9002-84-0	15-20	Not Available
Amorphous Silica	7631-86-9	1-5	Not Available

3. HEALTH HAZARD INFORMATION

- European Community Danger Group:..... None
- Special Hazards for man or environment: None
- LD₅₀/LC₅₀ Not Available

Routes of Entry

Skin Contact	Skin Absorption	Eye Contact	Inhalation	Ingestion
No	No	Yes	Yes	Yes

4. FIRST AID MEASURES

- If inhaled (Overexposure): If person is affected by fumes, remove person to fresh air. Seek medical attention.
- After contact with skin (Overexposure): Wash thoroughly with soap and water. If severe irritation develops, seek medical attention.
- After contact with eyes: Rinse thoroughly with water for 15 minutes, seek medical attention. Do not rub eyes.
- If swallowed: Seek medical attention.
- Medical information: Unlikely to cause ill effects. Inhaling fumes of decomposition products can cause temporary influenza-like symptoms which are described as “polymer fume fever”. Symptoms include fever, cough, and malaise.

5. FIRE FIGHTING MEASURES



MATERIAL SAFETY DATA SHEET

PURE GOOP™

November 2003

- Suitable extinguishing agents: Carbon dioxide, foam, agent suitable for environment.
- Not suitable for safety reasons: None known.
- Special dangers caused by substance preparation itself, by combustion products or gases formed: May decompose above 500°F/260°C to produce organo-chlorine compounds, organo-fluorine compounds, hydrogen fluoride, and chlorine gas.
- Additional information: None.

Auto ignition	UEL	LEL	Sensitivities
Not Applicable	Not Available	Not Available	Not Available

6. ACCIDENTAL RELEASE MEASURES

- Measures for protection of people: Put on necessary protective equipment. Eye and hand protection as needed.
- Measures for protection of the environment: None required.
- Cleaning measures: Use absorbent material and suitable cleaner.
- Additional information: None.

7. HANDLING AND STORAGE

- Safety information: None.
- Information on protection from fire: May decompose above 500°F/260°C to produce organo-chlorine compounds, organo-fluorine compounds, hydrogen fluoride, and chlorine gas.
- Additional information: Store in a cool, dry place for optimal product performance.

8. EXPOSURE CONTROLS AND PERSONAL PROTECTION

- Precautionary measures to protect employees: None required.
- Respiratory protection: None required.
- Hand protection: Rubber gloves are recommended to minimize exposure.
- Eye protection: Safety glasses or goggles are recommended to minimize exposure.
- Skin protection: Wash hands after use.



MATERIAL SAFETY DATA SHEET

PURE GOOP™

November 2003

9. PHYSICAL AND CHEMICAL PROPERTIES

Appearance Opaque-white	Odor Neutral	pH Not Applicable	Density 2.1 gm/cm ³	Vapor Pressure <0.01mm Hg
Boiling Point Not Available	Melting Point Not Available	Flash Point Not Available	Flammability Not Available	Explosive Not Applicable

10. STABILITY AND REACTIVITY

- Conditions to avoid: May decompose above 500°F/260°C to produce organo-chlorine or compounds, organo-fluorine compounds, hydrogen fluoride, and chlorine gas.
- Materials to avoid: Sodium, potassium, barium, calcium, finely divided zinc, aluminum, magnesium, and beryllium. Avoid aluminum-threaded connections where galling and seizure may initiate a reaction. Reacts with amines, liquid fluorine, and liquid chlorine trifluoride.
- Hazardous decomposition products: See Sections 4 and 5.

11. TOXICOLOGICAL INFORMATION

- Acute toxic properties: None known.
- Health effects: See Sections 4 and 5.
- Additional health effects: None known.

Sensitization	Teratogenicity	Reproductive Toxicity	Mutagenicity	Synergistic Products	Carcinogenicity
Not Available	Not Available	Not Available	Not Available	Not Available	Listed ingredients are not suspected carcinogens according to NTP, and IARC

12. ECOLOGICAL INFORMATION

- Mobility: Paste-like viscosity.
- Degradability: Not established.
- Accumulation: No known adverse bioaccumulation or biomagnification effects.
- Short / Long term effects on ecotoxicity: No known ecological effects.



MATERIAL SAFETY DATA SHEET

PURE GOOP™

November 2003

13. DISPOSAL CONSIDERATIONS

- Appropriate methods of disposal: Unused product not considered a hazardous waste in the United States. Dispose of in a responsible manner.
- European Community(EC) considerations: Use appropriate waste codes based on ingredients.

14. TRANSPORT INFORMATION

- Transport precautions: Consult applicable regulations when transporting this product
- Additional information: None.

15. REGULATORY INFORMATION

- EC regulations: This product has been classified under CHIP-96 guidelines based on chemical content.
- US/Canadian regulation listings: SARA 313 - NO, TSCA - YES, Canada's Controlled Products - NO
- EC Relevant risk: None.
- EC Relevant safety: S: 37/39 - Wear suitable gloves and eye/face protection.
S:20 - When using do not eat or drink.
- Additional information: Consult country codes for specific requirements.

16. OTHER INFORMATION

- Further information contact: Your Swagelok Distributor or the contacts listed in Section 1 of this sheet.
- Sources of information used to compile document: Properties of individual ingredients were used to compile this document. This Material Safety Data Sheet was designed to give the distributors and users of PURE GOOP information to handle and use the product in a responsible manner.

Preparation Data		
Environmental and Safety Department	(440) 349-5955	November 2003



LUBRIPLATE®

MATERIAL SAFETY DATA SHEET

Section 1

PRODUCT NAME OR NUMBER:

LUBRIPLATE Super FML-0, FML-1, FML-2

FORMULA:

Calcium Soap, USP Mineral Oil and Additives

GENERIC/CHEMICAL NAME:

Petroleum Lubricating Grease

NSF Registration No's:

125742, 125740, 125741

Manufacturer's Name:

Fiske Brothers Refining Co.

Emergency Telephone Number:

1-800-255-3924 - CHEM-TEL (24 hour)

Address:

1500 Oakdale Ave., Toledo, Ohio 43605 - 129 Lockwood St., Newark, NJ 07105

Telephone Number for Information:

419-691-2491 - Toledo Office

Section 2 - Hazardous Ingredients/Identity Information

<u>Hazardous Components</u>	<u>OSHA PEL</u>	<u>ACGIH TLV</u>	<u>Other Limits Recommended</u>	<u>% (optional)</u>
-----------------------------	-----------------	------------------	---------------------------------	---------------------

Non-hazardous

Hazardous Material Identification System (HMIS): Health - 1, Flammability - 1, Reactivity - 0**Not a Controlled Product under (WHMIS) - Canada****Special Protection: See Section 9**

Section 3 - Health Hazard Data

Threshold Limit Value: 5 mg/m³ for oil mist in air. OSHA Regulation 29 CFR 1910.1000**Effects of Overexposure:** Prolonged or repeated skin contact may cause skin irritation. Product contacting the eyes may cause eye irritation. Human health risks vary from person to person. As a precaution, exposure to liquids, vapors, mists and fumes should be minimized. This product has a low order of acute oral toxicity, but minute amounts aspirated into the lungs during ingestion may cause mild to severe pulmonary injury.**Carcinogenicity:** NTP? No IARC Monographs? No OSHA Regulated? No

Section 4 - Emergency and First Aid Procedures

EYE CONTACT: Flush with clear water for 15 minutes or until irritation subsides. If irritation persists, consult a physician.**SKIN CONTACT:** Remove any contaminated clothing and wash with soap and warm water. If injected by high pressure under skin, regardless of the appearance or its size, contact a physician IMMEDIATELY. Delay may cause loss of affected part of the body.**INHALATION:** Vapor pressure is very low and inhalation at room temperature is not a problem. If overcome by vapor from hot product, immediately remove from exposure and call a physician.**INGESTION:** If ingested, call a physician immediately. Do not induce vomiting.

Section 5 - Fire and Explosion Hazard Data

Flash Point (Method Used): COC - 435°F **Flammable Limits:** LEL 0.9% UEL 7.0%**Extinguishing Media:** Foam, Dry Chemical, Carbon Dioxide or Water Spray (Fog)**Special Fire Fighting Procedures:** Cool exposed containers with water. Use air-supplied breathing equipment for enclosed or confined spaces.**Unusual Fire and Explosion Hazards:** Do not store or mix with strong oxidants. Empty containers retain residue. Do not cut, drill, grind, or weld, as they may explode.

Section 6 - Physical/Chemical Characteristics

Boiling Point:	>550°F	Specific Gravity (H₂O = 1):	0.90 - 0.91
Vapor Pressure (mm Hg.):	<0.01	Melting Point:	Semi-solid
Vapor Density (AIR = 1):	>5	Evaporation Rate: (Butyl Acetate = 1)	<0.01
Solubility in Water:	Negligible		
Appearance and Odor:	Smooth, white grease with mineral oil odor.		

Section 7 - Reactivity Data

Stability:	Unstable Stable X	Conditions to Avoid:	N/A
Incompatibility (Materials to Avoid):	Avoid contact with strong oxidants like liquid chlorine, concentrated oxygen.		
Hazardous Decomposition or Byproducts:	May form SO ₂ . If incomplete combustion, Carbon Monoxide.		
Hazardous Polymerization:	May Occur Will Not Occur X	Conditions to Avoid:	N/A

Section 8 - Spill or Leak Procedures

Steps to be taken in case material is released or spilled:

Scrape up grease, wash remainder with suitable petroleum solvent or add absorbent. Keep petroleum products out of sewers and watercourses. Advise authorities if product has entered or may enter sewers and watercourses.

Waste disposal method:

Assure conformity with applicable disposal regulations. Dispose of absorbed material at an approved waste disposal facility or site.

SARA/TITLE III, Section 313 Status - Zinc Compounds - <6%

Section 9 - Special Protection Information

Respiratory Protection (Specify type):	Normally not needed		
Ventilation	Local Exhaust:	Used to capture fumes and vapors	Special: N/A
	Mechanical (General)		Other: N/A
Protective Gloves:	Use oil-resistant gloves, if needed.	Eye Protection:	If chance of eye contact, wear goggles.
Other Protective Equipment:	Use oil-resistant apron, if needed.		

Section 10 - Special Precautions

Precautions to be taken in handling and storing:

Keep containers closed when not in use. Do not handle or store near heat, sparks, flame, or strong oxidants.

Other Precautions:

Remove oil-soaked clothing and laundry before reuse. Cleanse skin thoroughly after contact.

The above information is furnished without warranty, expressed or implied, except that it is accurate to the best knowledge of Fiske Brothers Refining Company. The data on these sheets relates only to the specific material designated herein. Fiske Brothers Refining Company assumes no legal responsibility for use or reliance upon this data.

JL-M MATERIAL SAFETY DATA SHEET

SECTION 1 – PRODUCT IDENTIFICATION				
Product Name: JL-M Lubricant Revised: 03/07/03 Supercedes: 03/17/00 Prepared by: C. Semerod Emergency Information: (412) 279-1149	Manufacturer's Name: Superbolt, Inc. Manufacturer's Address: 1000 Gregg Street Carnegie, PA 15106 Manufacturer's Phone #: (412) 279-1149			
SECTION 2 – HAZARDOUS INGREDIENTS				
CHEMICAL NAME:	CAS NO.:	OSHA PEL:	ACGIH TLV:	(STEL)
Molybdenum Disulfide	1317-33-5	10 mg/m3	10 mg/m3	N/A
Silica, Fused	60676-86-0	0.1 mg/m3	0.1 mg/m3	N/A
Graphite	7782-42-5		2 mg/m3	N/A
Silica, Crystalline	14808-60-7		0.1 mg/m3	N/A
Lubricating Oils, Petroleum, Hydrotreated, Spent	64742-58-1	5 mg/m3*	5 mg/m3*	10mg/m3*
Residual Oils (Petroleum), Solvent Dewaxed	64742-62-7	5 mg/m3*	5 mg/m3*	10 mg/m3*
Solvent-Refined Heavy Paraffinic Distillate (Petroleum)	64741-88-4	5 mg/m3*	5 mg/m3*	10 mg/m3*
Solvent –Dewaxed Hydrotreated Heavy Paraffinic Distillate (Petroleum)	64742-65-0	5 mg/m3*	5 mg/m3*	10 mg/m3*
Hydrotreated Heavy Paraffinic Distillate (Petroleum)	64742-54-7	5 mg/m3*	5 mg/m3*	10 mg/m3*
Proprietary Additives Mixture (<1%)				
(*) Designates limits set by OSHA and the ACGIH for oil mist. This product is sold in a paste form so misting should not occur.				
SECTION 3 – PHYSICAL DATA		SECTION 4 – FIRE AND EXPLOSION DATA		
Appearance and Odor: Dark Grey Paste, Mild Petroleum Boiling Point: > 500 degrees F % Volatile: 0% Vapor Density: > 1 (Air = 1) Evaporation Rate: < 1 (Ether = 1) Specific Gravity: 4.8 (Water = 1) Vapor Pressure: Essentially 0 (mm Hg) Solubility in Water: Insoluble pH: N/A		Flash Point: 338 degrees F Lower Explosive Limit: N/A Upper Explosive Limit: N/A Extinguishing Media: Carbon Dioxide, Regular Foam, Dry Chemical Special Fire Fighting Procedures: Fire may produce dense smoke, firefighters should wear self contained breathing apparatus. Use water to cool fire exposed containers. Unusual Fire & Explosion Hazards: Decomposition and combustion by-products may be toxic. Heated containers may rupture or explode.		
SECTION 5 – REACTIVITY DATA		SECTION 6 – STORAGE & HANDLING		
Stability: Stable Hazardous Polymerization: Will not occur. Incompatibility: Avoid contact with oxidizing agents, heat, sparks or flame. Hazardous Combustion By-Products: Carbon Monoxide, Sulfur Dioxide, Aldehydes, and Nitrogen Oxides Hazardous Decomposition: Thermal decomposition may yield methacrylate monomers.		Handling Precautions: Use good personal hygiene practices. Clean contaminated clothing and protective equipment before reuse. Storage Precautions: Store in a cool dry location. Keep container tightly closed when not in use and during transport. Keep away from open sparks or flames.		
SECTION 7 – HEALTH HAZARDS				
Effects of Overexposure: Skin: May Cause Irritation Eyes: Eye Irritant. May cause redness and Blurred vision. Ingestion: Not Expected Inhalation: Not Expected (Chronic respiratory diseases may be aggravated by dust exposure.) NFPA CODES: Health: 1 Flammability: 1 Reactivity: 0 Carcinogenicity: Silica is a suspected carcinogen in a respirable form by the IARC and NTP however, not by the ACIGH or OSHA.		First Aid Procedures: Skin: Remove contaminated clothing from irritated area. Flush exposed area with mild soap and water. Seek medical attention if irritation persists. Eyes: Flush eyes with large quantities of water, holding eyelids open. Seek medical attention if irritation persists. Ingestion: Do not induce vomiting. If spontaneous vomiting occurs, keep head below hips to avoid aspiration into the lungs. Seek immediate medical attention. Inhalation: Remove to fresh air. Obtain medical attention if necessary.		
SECTION 8 – SPECIAL PROTECTION		SECTION 9 – SPILL AND DISPOSAL PROCEDURES		
Eye Protection: Safety Glasses or Face Shield Protective Gloves: Recommended Respiratory Protection: Avoid breathing dust, use an approved respirator if levels exceed OSHA limits. Ventilation: Local ventilation to maintain levels within OSHA limits.		Spill Procedures: Scrape or wipe up any spilled material. Wear proper protective equipment when cleaning up a spill. Disposal Procedures: Dispose of in accordance with any applicable federal, state, or local laws.		

The information in this MSDS was obtained from sources which we believe are reliable. However, the information is provided without any representation or warranty, expressed or implied, regarding the accuracy or correctness. The conditions or methods of handling, storage, use and disposal of the product are beyond our control. For this and other reasons, we do not assume responsibility and expressly disclaim liability for loss, damage, or expense arising out of or in any way connected with the handling, storage, use or disposal of the product.



Revision Number: 006.0

Issue date: 01/11/2012

1. PRODUCT AND COMPANY IDENTIFICATION

Product name:	Loctite(R) 242(R) Threadlocker Medium Strength	IDH number:	230718
Product type:	Anaerobic Sealant	Item number:	24205
Company address:	Henkel Corporation One Henkel Way Rocky Hill, Connecticut 06067	Region:	United States
		Contact information:	Telephone: 860.571.5100 MEDICAL EMERGENCY Phone: Poison Control Center 1-877-671-4608 (toll free) or 1-303-592-1711 TRANSPORT EMERGENCY Phone: CHEMTREC 1-800-424-9300 (toll free) or 1-703-527-3887 Internet: www.henkelna.com

2. HAZARDS IDENTIFICATION

EMERGENCY OVERVIEW

Physical state:	Liquid	HEALTH:	*2
Color:	Blue	FLAMMABILITY:	1
Odor:	Mild	PHYSICAL HAZARD:	1
		Personal Protection:	See MSDS Section 8

WARNING: CAUSES EYE IRRITATION.
MAY CAUSE SKIN IRRITATION.
MAY CAUSE ALLERGIC SKIN REACTION.
MAY CAUSE RESPIRATORY TRACT IRRITATION.

Relevant routes of exposure: Skin, Inhalation, Eyes

Potential Health Effects

Inhalation:	May cause respiratory tract irritation.
Skin contact:	May cause allergic skin reaction. May cause skin irritation.
Eye contact:	Contact with eyes will cause irritation.
Ingestion:	Not expected to be harmful by ingestion.

Existing conditions aggravated by exposure: Eye, skin, and respiratory disorders.

This material is considered hazardous by the OSHA Hazard Communication Standard (29 CFR 1910.1200).

See Section 11 for additional toxicological information.

3. COMPOSITION / INFORMATION ON INGREDIENTS

Hazardous components	CAS NUMBER	%
Polyglycol dimethacrylate	25852-47-5	60 - 100
Oleic acid 5.5EO	9004-96-0	10 - 30
Saccharin	81-07-2	1 - 5
Silica, amorphous, fumed, crystal-free	112945-52-5	1 - 5
Cumene hydroperoxide	80-15-9	1 - 5
Propanediol-1,2	57-55-6	1 - 5
Titanium dioxide	13463-67-7	0.1 - 1
Cumene	98-82-8	0.1 - 1

IDH number: 230718

Product name: Loctite(R) 242(R) Threadlocker Medium Strength
Page 1 of 6

4. FIRST AID MEASURES

Inhalation:	Move to fresh air. If breathing is difficult, give oxygen. If breathing has stopped, give artificial respiration. Keep warm and quiet. Get medical attention.
Skin contact:	Wash with soap and water. Remove contaminated clothing and footwear. Wash clothing before reuse. If symptoms develop and persist, get medical attention.
Eye contact:	Flush with copious amounts of water, preferably, lukewarm water for at least 15 minutes, holding eyelids open all the time. Get medical attention.
Ingestion:	Do not induce vomiting. Keep individual calm. Get medical attention.

5. FIRE FIGHTING MEASURES

Flash point:	> 93.3 °C (> 199.94 °F) Tagliabue closed cup
Flame projection:	Not applicable
Autoignition temperature:	Not determined
Flammable/Explosive limits - lower:	2.6 % (propylene glycol)
Flammable/Explosive limits - upper:	12.5 % (propylene glycol)
Extinguishing media:	Foam, dry chemical or carbon dioxide.
Special firefighting procedures:	None
Unusual fire or explosion hazards:	None
Hazardous combustion products:	Oxides of carbon. Oxides of sulfur. Oxides of nitrogen. Irritating organic vapours.

6. ACCIDENTAL RELEASE MEASURES

Use personal protection recommended in Section 8, isolate the hazard area and deny entry to unnecessary and unprotected personnel.

Environmental precautions:	Do not allow product to enter sewer or waterways.
Clean-up methods:	Soak up with inert absorbent material (e.g. sand, silica gel, acid binder, universal binder, sawdust). Store in a partly filled, closed container until disposal.

7. HANDLING AND STORAGE

Handling:	Prevent contact with eyes, skin and clothing. Do not breathe vapor and mist. Wash thoroughly after handling.
Storage:	For safe storage, store at or below 38 °C (100.4 °F) Keep in a cool, well ventilated area away from heat, sparks and open flame. Keep container tightly closed until ready for use.

For information on product shelf life contact Henkel Customer Service at (800) 243-4874.

8. EXPOSURE CONTROLS / PERSONAL PROTECTION

Employers should complete an assessment of all workplaces to determine the need for, and selection of, proper exposure controls and protective equipment for each task performed.

Hazardous components	ACGIH TLV	OSHA PEL	AIHA WEEL	OTHER
Polyglycol dimethacrylate	None	None	None	None
Oleic acid 5.5EO	None	None	None	None
Saccharin	None	None	None	None
Silica, amorphous, fumed, crystal-free	10 mg/m3 TWA Inhalable dust. 3 mg/m3 TWA Respirable fraction.	20 MPPCF TWA 0.8 mg/m3 TWA	None	None
Cumene hydroperoxide	None	None	1 ppm (6 mg/m3) TWA (SKIN)	None
Propanediol-1,2	None	None	10 mg/m3 TWA Aerosol.	None
Titanium dioxide	10 mg/m3 TWA	15 mg/m3 TWA Total dust.	None	None
Cumene	50 ppm TWA	50 ppm (245 mg/m3) TWA (SKIN)	None	None

Engineering controls:

No specific ventilation requirements noted, but forced ventilation may still be required if concentrations exceed occupational exposure limits.

Respiratory protection:

Use NIOSH approved respirator if there is potential to exceed exposure limit(s).

Eye/face protection:

Safety goggles or safety glasses with side shields.

Skin protection:

Use impermeable gloves and protective clothing as necessary to prevent skin contact. Neoprene gloves. Butyl rubber gloves. Natural rubber gloves.

9. PHYSICAL AND CHEMICAL PROPERTIES

Physical state:	Liquid
Color:	Blue
Odor:	Mild
Odor threshold:	Not available.
pH:	Not applicable
Vapor pressure:	< 5 mm hg (27 °C (80.6 °F))
Boiling point/range:	> 149 °C (> 300.2 °F)
Melting point/ range:	Not available.
Specific gravity:	1.1 at 23.9 °C (75.02 °F)
Vapor density:	Not available.
Flash point:	> 93.3 °C (> 199.94 °F) Tagliabue closed cup
Flame projection:	Not applicable
Flammable/Explosive limits - lower:	2.6 % (propylene glycol)
Flammable/Explosive limits - upper:	12.5 % (propylene glycol)
Autoignition temperature:	Not determined
Evaporation rate:	Not available.
Solubility in water:	Slight
Partition coefficient (n-octanol/water):	Not available.
VOC content:	4.48 %; 49.3 g/l EPA Method 24

10. STABILITY AND REACTIVITY

Stability:	Stable
Hazardous reactions:	Will not occur.
Hazardous decomposition products:	Oxides of carbon. Oxides of sulfur. Oxides of nitrogen. Irritating organic vapours.
Incompatible materials:	Strong oxidizing agents. Free radical initiators. Strong reducing agents. Alkalis. Oxygen scavengers. Other polymerization initiators. Copper. Iron. Zinc. Aluminum. Rust.
Conditions to avoid:	See "Handling and Storage" (Section 7) and "Incompatibility" (Section 10).

11. TOXICOLOGICAL INFORMATION

Acute oral product toxicity:	LD50 (rat) > 10,000 mg/kg
Acute dermal product toxicity:	LD50 (rabbit) > 5,000 mg/kg

Hazardous components	NTP Carcinogen	IARC Carcinogen	OSHA Carcinogen (Specifically Regulated)
Polyglycol dimethacrylate	No	No	No
Oleic acid 5.5EO	No	No	No
Saccharin	No	No	No
Silica, amorphous, fumed, crystal-free	No	No	No
Cumene hydroperoxide	No	No	No
Propanediol-1,2	No	No	No
Titanium dioxide	No	Group 2B	No
Cumene	No	Group 2B	No

Hazardous components	Health Effects/Target Organs
Polyglycol dimethacrylate	Irritant, Allergen
Oleic acid 5.5EO	Irritant
Saccharin	No Target Organs
Silica, amorphous, fumed, crystal-free	Nuisance dust
Cumene hydroperoxide	Allergen, Central nervous system, Corrosive, Irritant, Mutagen
Propanediol-1,2	Irritant
Titanium dioxide	Irritant, Respiratory, Some evidence of carcinogenicity
Cumene	Central nervous system, Irritant, Lung

12. ECOLOGICAL INFORMATION

Ecological information:	Not available.
--------------------------------	----------------

13. DISPOSAL CONSIDERATIONS

Information provided is for unused product only.

Recommended method of disposal: Follow all local, state, federal and provincial regulations for disposal.

Hazardous waste number: Not a RCRA hazardous waste.

14. TRANSPORT INFORMATION

The shipping classifications in this sections are for non-bulk packaging only (unless otherwise specified). Shipping classification may be different for bulk packaging.

U.S. Department of Transportation Ground (49 CFR)

Proper shipping name: Not regulated
Hazard class or division: None
Identification number: None
Packing group: None

International Air Transportation (ICAO/IATA)

Proper shipping name: Not regulated
Hazard class or division: None
Identification number: None
Packing group: None

Water Transportation (IMO/IMDG)

Proper shipping name: Not regulated
Hazard class or division: None
Identification number: None
Packing group: None

15. REGULATORY INFORMATION

United States Regulatory Information

TSCA 8 (b) Inventory Status: All components are listed or are exempt from listing on the Toxic Substances Control Act Inventory.

TSCA 12(b) Export Notification: None above reporting de minimus

CERCLA/SARA Section 302 EHS: None above reporting de minimus

CERCLA/SARA Section 311/312: Immediate Health, Delayed Health

CERCLA/SARA 313: This product contains the following toxic chemicals subject to the reporting requirements of section 313 of the Emergency Planning and Community Right-To-Know Act of 1986 (40 CFR 372). Cumene hydroperoxide (CAS# 80-15-9).

California Proposition 65: This product contains a chemical known in the State of California to cause cancer. This product contains a chemical known to the State of California to cause birth defects or other reproductive harm.

Canada Regulatory Information

CEPA DSL/NDSL Status: All components are listed on or are exempt from listing on the Canadian Domestic Substances List.

WHMIS hazard class: D.2.A, D.2.B

16. OTHER INFORMATION

This material safety data sheet contains changes from the previous version in sections: 3, 8, 11

Prepared by: Kyra Kozak Woods, Manager, Regulatory Affairs

DISCLAIMER: The data contained herein are furnished for information only and are believed to be reliable. However, Henkel Corporation and its affiliates ("Henkel") does not assume responsibility for any results obtained by persons over whose methods Henkel has no control. It is the user's responsibility to determine the suitability of Henkel's products or any production methods mentioned herein for a particular purpose, and to adopt such precautions as may be advisable for the protection of property and persons against any hazards that may be involved in the handling and use of any Henkel's products. In light of the foregoing, Henkel specifically disclaims all warranties, express or implied, including warranties of merchantability and fitness for a particular purpose, arising from sale or use of Henkel's products. Henkel further disclaims any liability for consequential or incidental damages of any kind, including lost profits.

Material Safety Data Sheet**1. MATERIAL AND COMPANY IDENTIFICATION**

Material Name : Morlina® Oil SD 100

Manufacturer/Supplier : SOPUS Products
PO BOX 4427
Houston, TX 77210-4427
USA

MSDS Request : 877-276-7285

Emergency Telephone Number
Spill Information : 877-242-7400
Health Information : 877-504-9351

2. COMPOSITION/INFORMATION ON INGREDIENTS

Highly refined mineral oils and additives.
The highly refined mineral oil contains <3% (w/w) DMSO-extract, according to IP346.

3. HAZARDS IDENTIFICATION

Emergency Overview	
Appearance and Odour	: Clear pale yellow. Liquid at room temperature. Slight hydrocarbon.
Health Hazards	: Not classified as dangerous for supply or conveyance.
Safety Hazards	: Not classified as flammable but will burn.
Environmental Hazards	: Not classified as dangerous for the environment.

Health Hazards : Not expected to be a health hazard when used under normal conditions.

Health Hazards
Inhalation : Under normal conditions of use, this is not expected to be a primary route of exposure.

Skin Contact : Prolonged or repeated skin contact without proper cleaning can clog the pores of the skin resulting in disorders such as oil acne/folliculitis.

Eye Contact : May cause slight irritation to eyes.

Ingestion : Low toxicity if swallowed.

Other Information : Used oil may contain harmful impurities.

Signs and Symptoms : Oil acne/folliculitis signs and symptoms may include formation of black pustules and spots on the skin of exposed areas. Ingestion may result in nausea, vomiting and/or diarrhoea.

Aggravated Medical Condition : Pre-existing medical conditions of the following organ(s) or organ system(s) may be aggravated by exposure to this material: Skin.

Environmental Hazards : Not classified as dangerous for the environment.

Additional Information : Under normal conditions of use or in a foreseeable emergency,

Material Safety Data Sheet

this product does not meet the definition of a hazardous chemical when evaluated according to the OSHA Hazard Communication Standard, 29 CFR 1910.1200.

4. FIRST AID MEASURES

General Information	:	Not expected to be a health hazard when used under normal conditions.
Inhalation	:	No treatment necessary under normal conditions of use. If symptoms persist, obtain medical advice.
Skin Contact	:	Remove contaminated clothing. Flush exposed area with water and follow by washing with soap if available. If persistent irritation occurs, obtain medical attention.
Eye Contact	:	Flush eye with copious quantities of water. If persistent irritation occurs, obtain medical attention.
Ingestion	:	In general no treatment is necessary unless large quantities are swallowed, however, get medical advice.
Advice to Physician	:	Treat symptomatically.

5. FIRE FIGHTING MEASURES

Clear fire area of all non-emergency personnel.

Flash point	:	Typical 218 °C / 424 °F (COC)
Upper / lower Flammability or Explosion limits	:	Typical 1 - 10 %(V)(based on mineral oil)
Auto ignition temperature	:	> 320 °C / 608 °F
Specific Hazards	:	Hazardous combustion products may include: A complex mixture of airborne solid and liquid particulates and gases (smoke). Carbon monoxide. Unidentified organic and inorganic compounds.
Suitable Extinguishing Media	:	Foam, water spray or fog. Dry chemical powder, carbon dioxide, sand or earth may be used for small fires only.
Unsuitable Extinguishing Media	:	Do not use water in a jet.
Protective Equipment for Firefighters	:	Proper protective equipment including breathing apparatus must be worn when approaching a fire in a confined space.

6. ACCIDENTAL RELEASE MEASURES

Avoid contact with spilled or released material. For guidance on selection of personal protective equipment see Chapter 8 of this Material Safety Data Sheet. See Chapter 13 for information on disposal. Observe all relevant local and international regulations.

Protective measures	:	Avoid contact with skin and eyes. Use appropriate containment to avoid environmental contamination. Prevent from spreading or entering drains, ditches or rivers by using sand, earth, or other appropriate barriers.
Clean Up Methods	:	Slippery when spilt. Avoid accidents, clean up immediately. Prevent from spreading by making a barrier with sand, earth or other containment material. Reclaim liquid directly or in an

Material Safety Data Sheet

- absorbent. Soak up residue with an absorbent such as clay, sand or other suitable material and dispose of properly.
- Additional Advice** : Local authorities should be advised if significant spillages cannot be contained.

7. HANDLING AND STORAGE

- General Precautions** : Use local exhaust ventilation if there is risk of inhalation of vapours, mists or aerosols. Properly dispose of any contaminated rags or cleaning materials in order to prevent fires. Use the information in this data sheet as input to a risk assessment of local circumstances to help determine appropriate controls for safe handling, storage and disposal of this material.
- Handling** : Avoid prolonged or repeated contact with skin. Avoid inhaling vapour and/or mists. When handling product in drums, safety footwear should be worn and proper handling equipment should be used.
- Storage** : Keep container tightly closed and in a cool, well-ventilated place. Use properly labelled and closeable containers. Storage Temperature: 0 - 50 °C / 32 - 122 °F
- Recommended Materials** : For containers or container linings, use mild steel or high density polyethylene.
- Unsuitable Materials** : PVC.
- Additional Information** : Polyethylene containers should not be exposed to high temperatures because of possible risk of distortion.

8. EXPOSURE CONTROLS/PERSONAL PROTECTION**Occupational Exposure Limits**

Material	Source	Type	ppm	mg/m3	Notation
Oil mist, mineral	ACGIH	TWA(Mist.)		5 mg/m3	
Oil mist, mineral	ACGIH	STEL(Mist.)		10 mg/m3	

- Exposure Controls** : The level of protection and types of controls necessary will vary depending upon potential exposure conditions. Select controls based on a risk assessment of local circumstances. Appropriate measures include: Adequate ventilation to control airborne concentrations. Where material is heated, sprayed or mist formed, there is greater potential for airborne concentrations to be generated.
- Personal Protective Equipment** : Personal protective equipment (PPE) should meet recommended national standards. Check with PPE suppliers.
- Respiratory Protection** : No respiratory protection is ordinarily required under normal conditions of use. In accordance with good industrial hygiene practices, precautions should be taken to avoid breathing of material. If engineering controls do not maintain airborne

Material Safety Data Sheet

- concentrations to a level which is adequate to protect worker health, select respiratory protection equipment suitable for the specific conditions of use and meeting relevant legislation. Check with respiratory protective equipment suppliers. Where air-filtering respirators are suitable, select an appropriate combination of mask and filter. Select a filter suitable for combined particulate/organic gases and vapours [boiling point >65°C(149 °F)].
- Hand Protection** : Where hand contact with the product may occur the use of gloves approved to relevant standards (e.g. Europe: EN374, US: F739) made from the following materials may provide suitable chemical protection: PVC, neoprene or nitrile rubber gloves. Suitability and durability of a glove is dependent on usage, e.g. frequency and duration of contact, chemical resistance of glove material, glove thickness, dexterity. Always seek advice from glove suppliers. Contaminated gloves should be replaced. Personal hygiene is a key element of effective hand care. Gloves must only be worn on clean hands. After using gloves, hands should be washed and dried thoroughly. Application of a non-perfumed moisturizer is recommended.
- Eye Protection** : Wear safety glasses or full face shield if splashes are likely to occur.
- Protective Clothing** : Skin protection not ordinarily required beyond standard issue work clothes.
- Monitoring Methods** : Monitoring of the concentration of substances in the breathing zone of workers or in the general workplace may be required to confirm compliance with an OEL and adequacy of exposure controls. For some substances biological monitoring may also be appropriate.
- Environmental Exposure Controls** : Minimise release to the environment. An environmental assessment must be made to ensure compliance with local environmental legislation.

9. PHYSICAL AND CHEMICAL PROPERTIES

- Appearance : Clear pale yellow. Liquid at room temperature.
- Odour : Slight hydrocarbon.
- pH : Not applicable.
- Initial Boiling Point and Boiling Range : > 280 °C / 536 °F estimated value(s)
- Pour point : Typical 0 °C / 32 °F
- Flash point : Typical 218 °C / 424 °F (COC)
- Upper / lower Flammability or Explosion limits : Typical 1 - 10 %(V) (based on mineral oil)
- Auto-ignition temperature : > 320 °C / 608 °F
- Vapour pressure : < 0.5 Pa at 20 °C / 68 °F (estimated value(s))
- Specific gravity : Typical 0.88
- Density : Typical 7.49 g/cm³
- Water solubility : Negligible.
- n-octanol/water partition coefficient (log Pow) : > 6 (based on information on similar products)
- Kinematic viscosity : Typical 100 mm²/s at 40 °C / 104 °F

Material Safety Data Sheet

Vapour density (air=1) : > 1 (estimated value(s))
Evaporation rate (nBuAc=1) : Data not available

10. STABILITY AND REACTIVITY

Stability : Stable.
Conditions to Avoid : Extremes of temperature and direct sunlight.
Materials to Avoid : Strong oxidising agents.
Hazardous Decomposition Products : Hazardous decomposition products are not expected to form during normal storage.
Hazardous Polymerisation : Data not available
Sensitivity to Mechanical Impact : Data not available
Sensitivity to Static Discharge : Data not available

11. TOXICOLOGICAL INFORMATION

Basis for Assessment : Information given is based on data on the components and the toxicology of similar products.
Acute Oral Toxicity : Expected to be of low toxicity: LD50 > 5000 mg/kg
Acute Dermal Toxicity : Expected to be of low toxicity: LD50 > 5000 mg/kg
Acute Inhalation Toxicity : Not considered to be an inhalation hazard under normal conditions of use.
Skin Irritation : Expected to be slightly irritating.
Eye Irritation : Expected to be slightly irritating.
Respiratory Irritation : Inhalation of vapours or mists may cause irritation.
Sensitisation : Not expected to be a skin sensitiser.
Repeated Dose Toxicity : Not expected to be a hazard.
Mutagenicity : Not considered a mutagenic hazard.
Carcinogenicity : Product contains mineral oils of types shown to be non-carcinogenic in animal skin-painting studies. Highly refined mineral oils are not classified as carcinogenic by the International Agency for Research on Cancer (IARC). Other components are not known to be associated with carcinogenic effects.
Reproductive and Developmental Toxicity : Not expected to be a hazard.
Additional Information : Used oils may contain harmful impurities that have accumulated during use. The concentration of such impurities will depend on use and they may present risks to health and the environment on disposal. ALL used oil should be handled with caution and skin contact avoided as far as possible.

12. ECOLOGICAL INFORMATION

Ecotoxicological data have not been determined specifically for this product. Information given is based on a knowledge of the components and the ecotoxicology of similar products.

Acute Toxicity : Poorly soluble mixture. May cause physical fouling of aquatic organisms. Expected to be practically non toxic: LL/EL/IL50 >

Material Safety Data Sheet

100 mg/l (to aquatic organisms) (LL/EL50 expressed as the nominal amount of product required to prepare aqueous test extract). Mineral oil is not expected to cause any chronic effects to aquatic organisms at concentrations less than 1 mg/l.

- Mobility** : Liquid under most environmental conditions. Floats on water. If it enters soil, it will adsorb to soil particles and will not be mobile.
- Persistence/degradability** : Expected to be not readily biodegradable. Major constituents are expected to be inherently biodegradable, but the product contains components that may persist in the environment.
- Bioaccumulation** : Contains components with the potential to bioaccumulate.
- Other Adverse Effects** : Product is a mixture of non-volatile components, which are not expected to be released to air in any significant quantities. Not expected to have ozone depletion potential, photochemical ozone creation potential or global warming potential.

13. DISPOSAL CONSIDERATIONS

- Material Disposal** : Recover or recycle if possible. It is the responsibility of the waste generator to determine the toxicity and physical properties of the material generated to determine the proper waste classification and disposal methods in compliance with applicable regulations. Do not dispose into the environment, in drains or in water courses.
- Container Disposal** : Dispose in accordance with prevailing regulations, preferably to a recognised collector or contractor. The competence of the collector or contractor should be established beforehand.
- Local Legislation** : Disposal should be in accordance with applicable regional, national, and local laws and regulations.

14. TRANSPORT INFORMATION

US Department of Transportation Classification (49CFR)

This material is not subject to DOT regulations under 49 CFR Parts 171-180.

IMDG

This material is not classified as dangerous under IMDG regulations.

IATA (Country variations may apply)

This material is not classified as dangerous under IATA regulations.

15. REGULATORY INFORMATION

The regulatory information is not intended to be comprehensive. Other regulations may apply to this material.

Federal Regulatory Status

Notification Status

Material Safety Data Sheet

EINECS All components listed.
TSCA All components listed.
DSL All components listed.

SARA Hazard Categories (311/312)

No SARA 311/312 Hazards.

State Regulatory Status

California Safe Drinking Water and Toxic Enforcement Act (Proposition 65)

This product contains a chemical known to the State of California to cause cancer.

16. OTHER INFORMATION

NFPA Rating (Health, Fire, Reactivity) : 0, 1, 0

MSDS Version Number : 7.1

MSDS Effective Date : 01/06/2009

MSDS Revisions : A vertical bar (|) in the left margin indicates an amendment from the previous version.

MSDS Regulation : The content and format of this MSDS is in accordance with the OSHA Hazard Communication Standard, 29 CFR 1910.1200.

MSDS Distribution : The information in this document should be made available to all who may handle the product.

Disclaimer : The information contained herein is based on our current knowledge of the underlying data and is intended to describe the product for the purpose of health, safety and environmental requirements only. No warranty or guarantee is expressed or implied regarding the accuracy of these data or the results to be obtained from the use of the product.